

Designed for precision and space savings, tubing and wiring can pass through the hollow hole, contributing to simpler and smaller equipment.

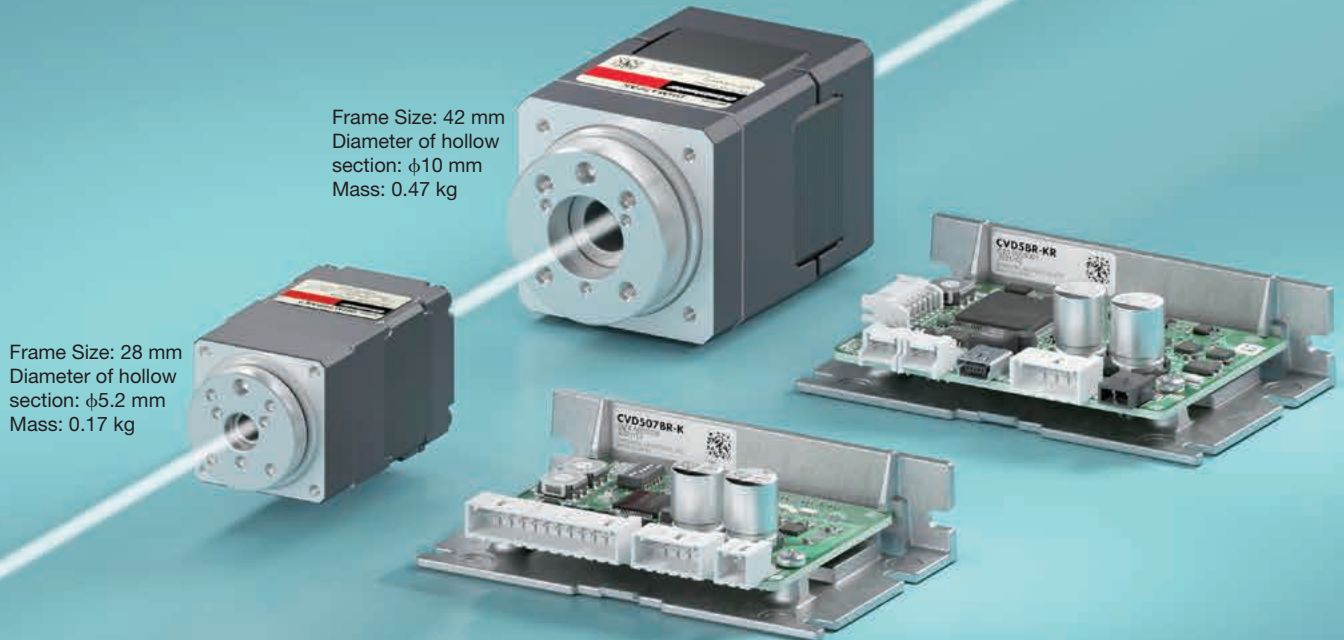

Frame Size: 42 mm
Diameter of hollow section: $\phi 10$ mm
Mass: 0.47 kg

Frame Size: 28 mm
Diameter of hollow section: $\phi 5.2$ mm
Mass: 0.17 kg

Actuators with a hollow rotor.

Tubing and wiring can be simplified, and the number of installation mechanism parts can be reduced.

This contributes to smaller and lighter equipment, as well as reduced design time.

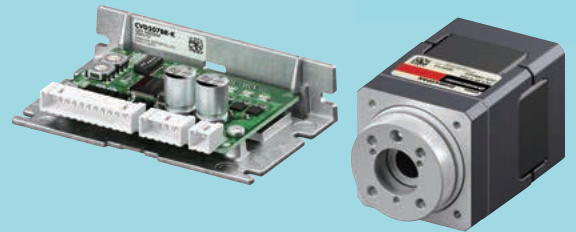

Hollow Rotary Actuators DH Series

The hollow portion simplifies the tubing and wiring of cutting-edge equipment

This actuator is a 5-phase stepper motor with a hollow flange. Tubing, wiring and light beams can be passed through the hollow part, contributing to simpler cutting-edge design, as well as smaller and lighter equipment.

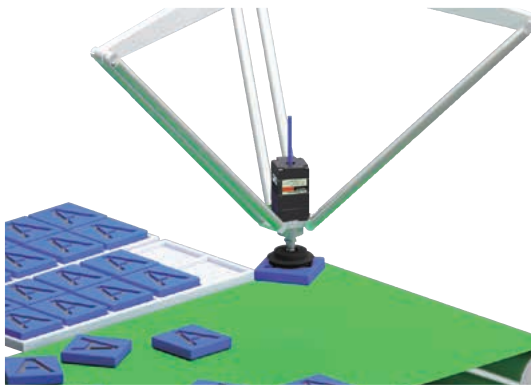

Parallel link robot
θ axis of suction device

● DH Series Structure

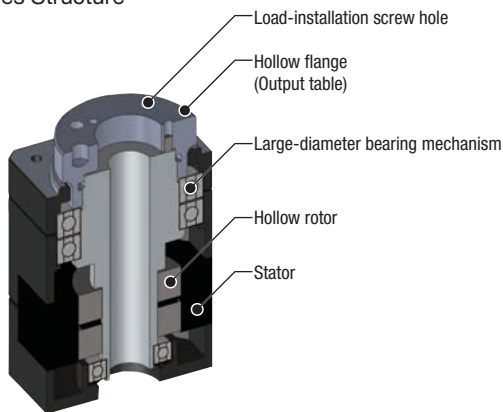

Product Name	Frame Size	Diameter of Hollow Section	Mass
DHM28PAK2	28 mm	φ5.2 mm	0.17 kg
DHM42PAK	42 mm	φ10 mm	0.47 kg

The flange installation reduces the number of parts around the moving parts

The hollow flange can be attached directly to the load. This reduces the number of parts around the moving parts.

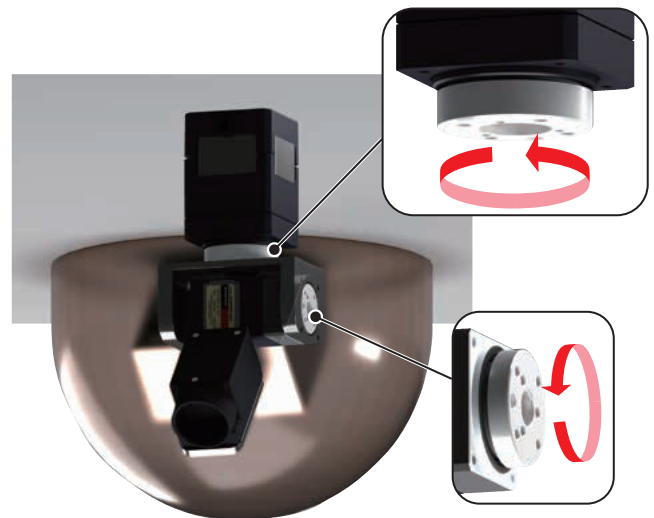

Axes of rotation of security camera

● Diameter of Hollow Section (Actual size)

Example: **DHM42PAK**

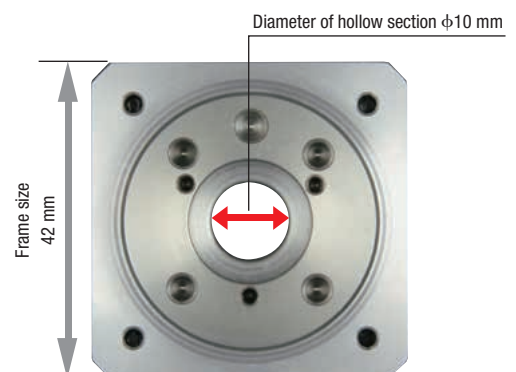

Some of the conventional parts have been eliminated, so the time required for equipment design and product selection is shortened. Furthermore, the number of man-hours required for assembly and the adjustment of installation accuracy can be reduced, contributing to higher productivity.

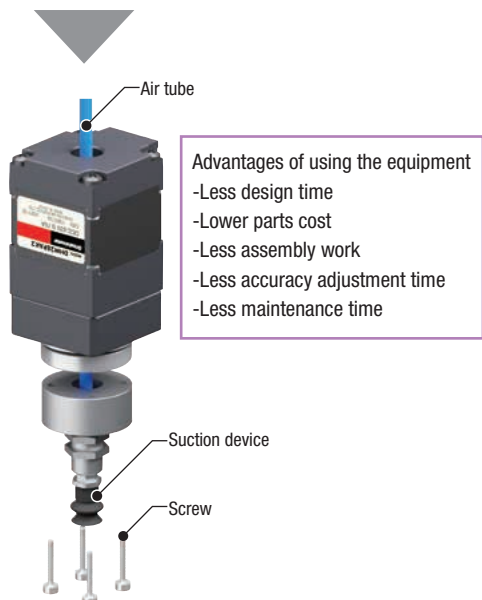
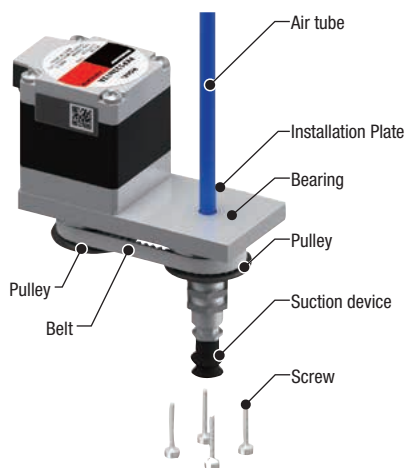

High Positioning Accuracy

The on-board 5-phase stepper motor allows for high positioning accuracy and fine operations to be stably repeated. Thanks to the microstep drive and smooth drive function in combination with the **CVD** driver, vibration is reduced at low speed and smooth operation is possible. Because the hollow flange does not use any transfer mechanisms like couplings or belts, there is no effect of error on accuracy caused by part rigidity or combination.

- Advantages of using the equipment
- Highly accurate parts alignment
 - Lighter suction unit
 - Smaller suction unit thanks to parallel configuration

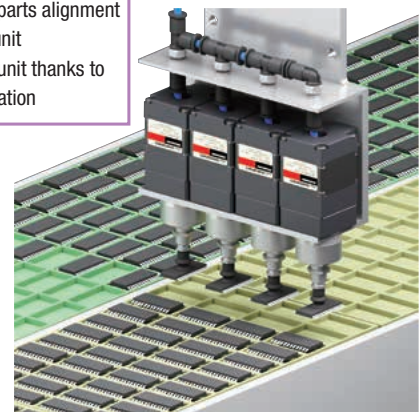

Part menter
θ axis of parallel suction device

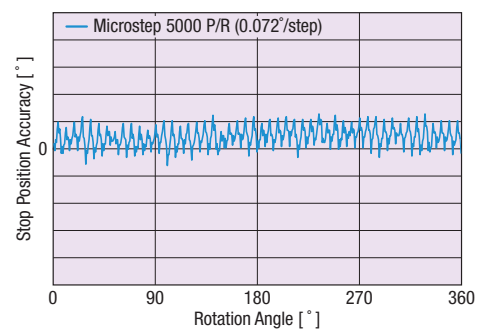

Product Name	Stop Position Accuracy	Repetitive Positioning Accuracy
DHM28PAK2	±0.33°	±0.15°
DHM42PAK	±0.11°	±0.05°

Combined Drivers

CVD Series drivers are available.

Refer to “**CVD Series 5-phase Stepper Motor Drivers (Combined Drivers)**” on page 12 for details.

Low Vibration Achieved by Full-Time Microstep Drive

Utilizing a digitally-controlled full-time microstep driver improves the vibration levels and reduces both vibration and noise at all speeds.

Industry's-Top-Class Compact High Performance Driver

- Compact and lightweight drivers that contribute to saving space
- Protective function that enables you to find driver errors early
- Smooth drive function that enables smoother operation
- Set the running current using a digital switch

Actual Size

Mass 20 g~70 g

(The value differs according to the driver type.)

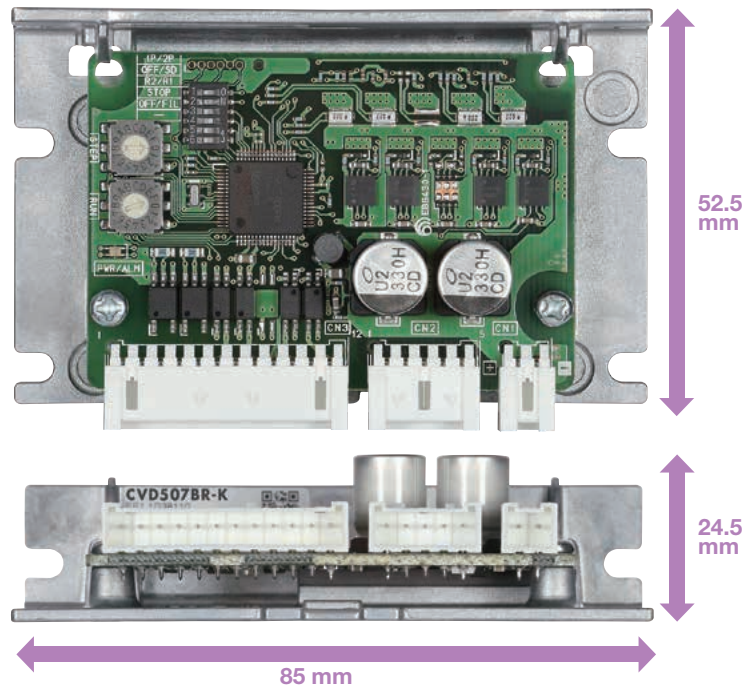

Wide Variety of Products According to System Configuration and Application

◇ Pulse Input Type

Synchronous operation is easy with pulse input.



Right Angle Type with Installation Plate



With Installation Plate

● Types without an installation plate are available.

◇ RS-485 Communication Type

Operation control and parameter settings are possible via RS-485 communication (Modbus RTU).

Since a pulse generator is not required, the operating data set in the driver can be selected and executed from the host control device.



Right Angle Type with Installation Plate



With Installation Plate

System Configuration

Combination of Hollow Rotary Actuator and CVD Series Pulse Input Type Driver

This is an example of system configuration using a programmable controller (with pulse oscillation function).

Hollow rotary actuators, drivers, and connection cables need to be ordered separately.

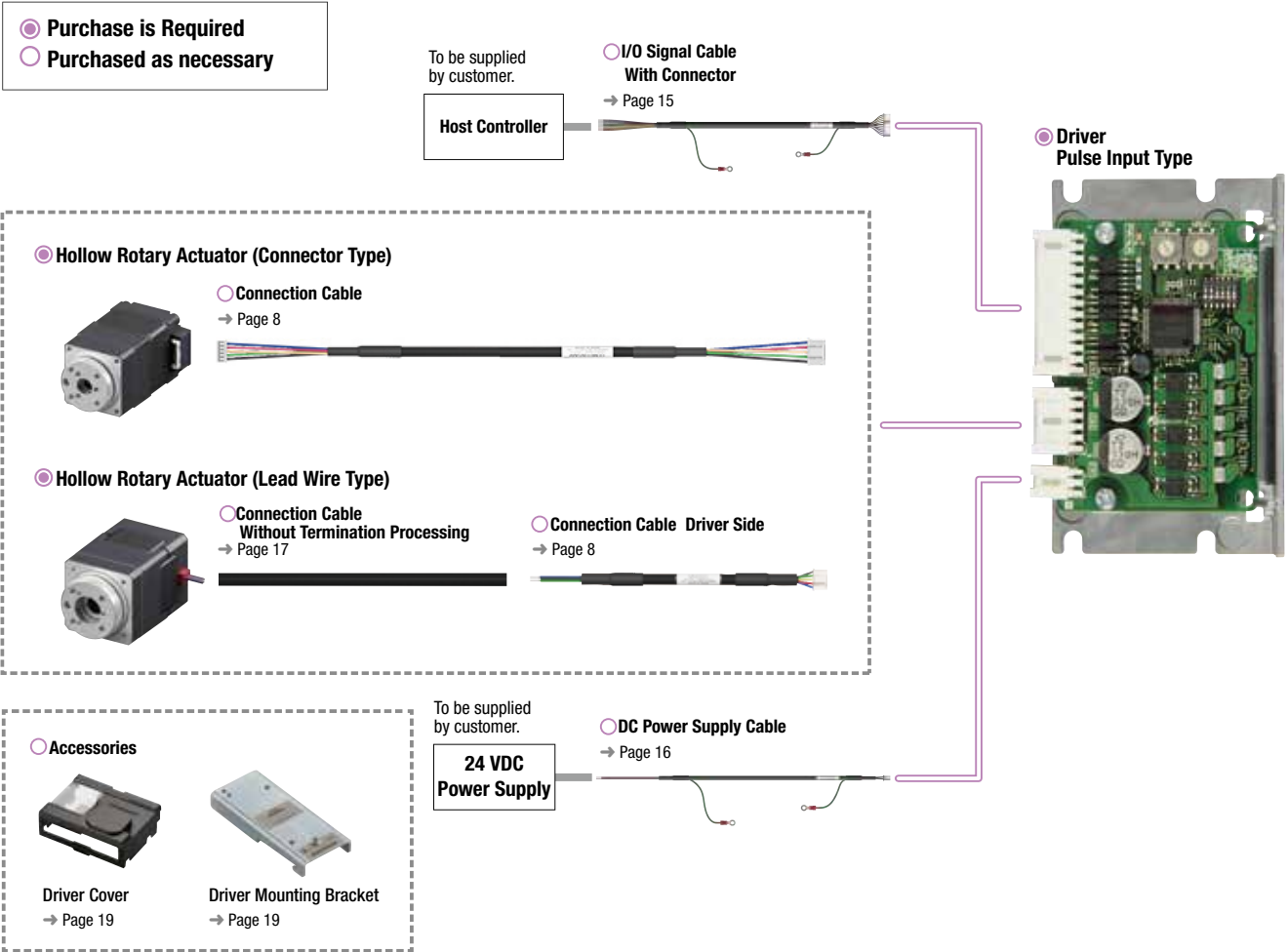

Example of System Configuration Pricing

Hollow Rotary Actuator	+	Driver	+	Cable		
				Connection Cables (1 m)	I/O Signal Cable Connector Type (1 m)	DC Power Supply Cable (1 m)
DHM28PAK2		CVD507BR-K		CCM010V5AAF	CC12D010-2	CC02D010-2
<input checked="" type="radio"/>		<input checked="" type="radio"/>		<input checked="" type="radio"/>	<input checked="" type="radio"/>	<input checked="" type="radio"/>

The system configuration shown above is an example. Other combinations are also available.

Note

The driver cover can be used for a pulse input type driver right-angle type with installation plate.

● **Combination of Hollow Rotary Actuator and CVD Series RS-485 Communication Type Driver**

An example of three-axis system configuration when controlled with RS-485 communication is shown below.

The hollow rotary actuators, drivers, and connection cables must be ordered separately.

- Purchase is required
- Purchased as necessary

To be supplied by customer.

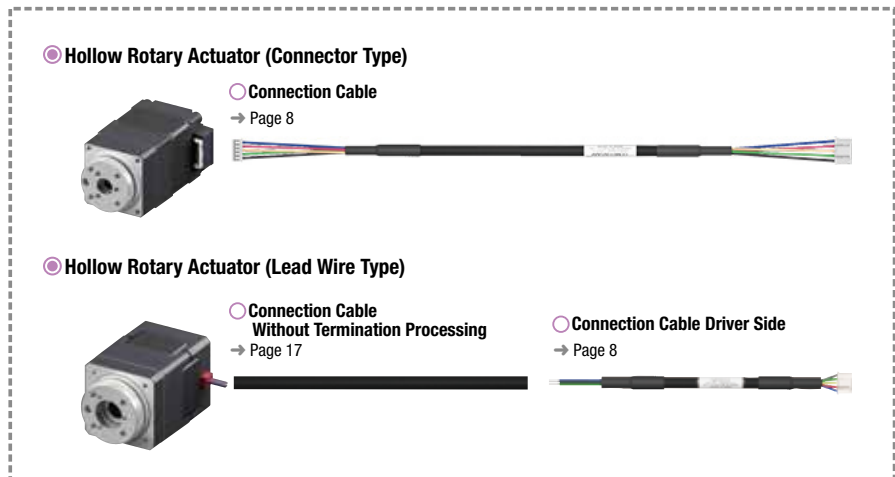
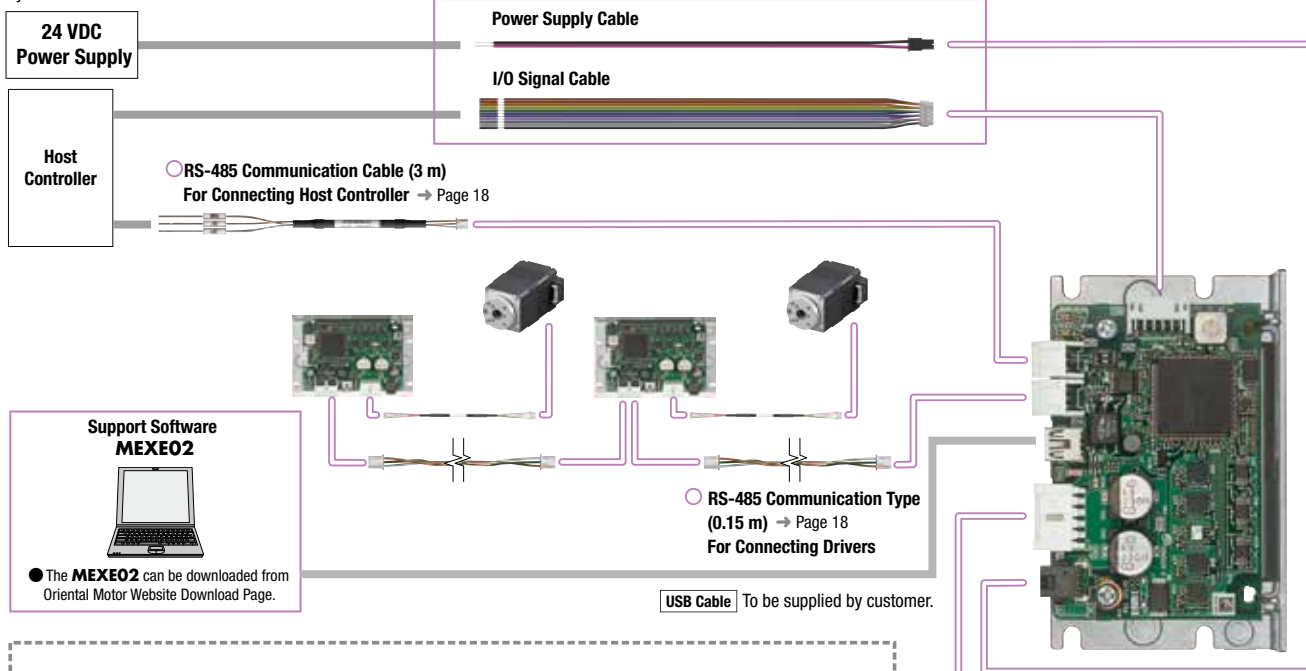

○ **Driver RS-485 Communication Type**

Note

Connectors for connecting power supply, motor, I/O signal cable, and RS-485 communication are not included with the driver. Accessory cables need to be purchased or connectors must be supplied separately by a customer. For connector product numbers, see page 13 on this brochure or refer to the operating manual.

● **Example of System Configuration Pricing**

Hollow Rotary Actuator	+	Driver	+	Cable		
				Connection Cable (1 m)	RS-485 Communication Cable (3 m)	Cable Set (0.3 m)
DHM28PAK2		CVD5BR-KR		CCM010V5AAF	CC030-RS	LHS003CC
○		○		○	○	○

● The system configuration shown above is an example. Other combinations are also available.

Cable System Configuration Example

This is an example of connection between the hollow rotary actuator (connector type) and our driver.

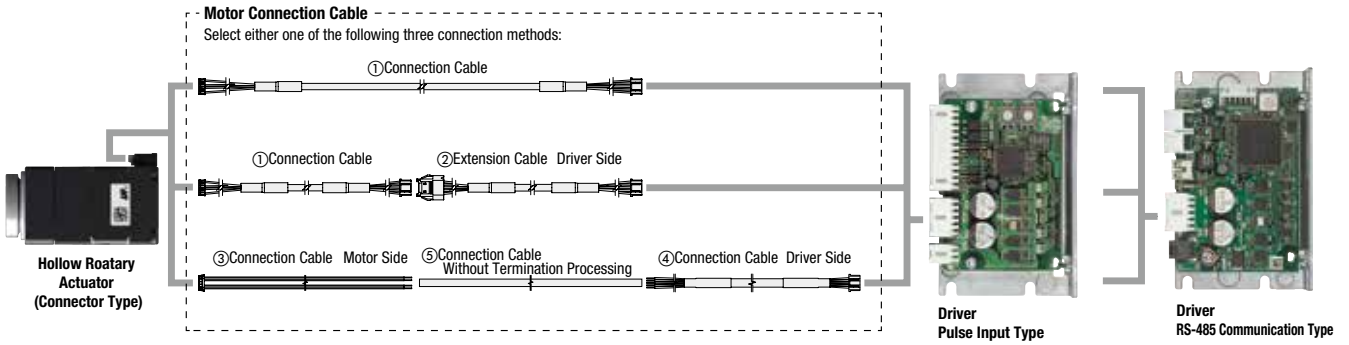

Selectable from the following three connection methods:

Connect using a connection cable

Connect by adding a extension cable to the connection cable

Use the connection cable motor side to connect to the connection cable driver side by a customer.

Note

- Up to 3 cables can be used to connect the motor and the driver.
- The distance between the motor and the driver can be extended up to 10 m.

Product Number

DHM 28 P A K 2

- ① ② ③ ④ ⑤ ⑥

①	Series Name	DHM: DH Series
②	Frame Size	28: 28 mm 42: 42 mm
③	Equipped Motor	P: 5-Phase Stepper Motor
④	Motor Type	A: Standard
⑤	Motor Specifications	K: DC Power Supply Input
⑥	Reference Number	

Product Line

Actuators, drivers, and cables need to be ordered separately. Please refer to page 12 for details of the drivers.

Actuators

Product Name
DHM28PAK2
DHM42PAK

Connection Cables / Flexible Connection Cables

◇ For Frame Size 28 mm

• Connection Cables

Product Name	Length L (m)
CCM005V5AAF	0.5
CCM010V5AAF	1
CCM015V5AAF	1.5
CCM020V5AAF	2
CCM025V5AAF	2.5
CCM030V5AAF	3
CCM040V5AAF	4
CCM050V5AAF	5
CCM070V5AAF	7
CCM100V5AAF	10

● Please refer to the **PKP** Series brochure for the "Extension cable driver side (**CCM□□□V5ADFT**)" to be added to the connection cable. The wiring distance between the motor and the driver should be 10 m or less.

◇ For Frame Size 42 mm

• Connection Cables Driver Side

Product Name	Length L (m)
CC005N1	0.5
CC010N1	1

● Connection cables without termination processing (**CC□□PK5, CC□□PK5R**) are for extending the connection between the motor and the driver. See page 17 for details. The wiring distance between the motor and the driver should be 10 m or less.

• Flexible Connection Cables

Product Name	Length L (m)
CCM005V5AAR	0.5
CCM010V5AAR	1
CCM015V5AAR	1.5
CCM020V5AAR	2
CCM025V5AAR	2.5
CCM030V5AAR	3
CCM040V5AAR	4
CCM050V5AAR	5
CCM070V5AAR	7
CCM100V5AAR	10

• Flexible Connection Cables Driver Side

Product Name	Length L (m)
CC005N1R	0.5
CC010N1R	1

Included

Operating Manual: 1 Copy

How to Read Specifications

Specifications

Frame Size		28 mm	42 mm	
Actuator Product Name		DHM28PAK2	DHM42PAK	
Driver Product Name	Pulse Input	CVD507BR-K		
	RS-485 Communication	CVD5BR-KR		
①	Maximum Holding Torque	N·m	0.029	0.175
②	Holding Torque at Motor Standstill	Power ON N·m	0.014	0.087
	Rotor Inertia	J : kg·m ²	3.5×10 ⁻⁶	25.5×10 ⁻⁶
	Rated Current	A/Phase	0.75	
	Basic Step Angle		0.72°	
	Stop Position Accuracy		±0.33°	±0.11°
③	Repetitive Positioning Accuracy		±0.15°	±0.05°
④	Permissible Axial Load	N	40	150
⑤	Permissible Moment Load	N·m	0.1	0.4
⑥	Runout of Output Table (Hollow Flange) Surface	mm	0.05	
⑦	Runout of Output Table (Hollow Flange) Inner/Outer Diameter	mm	0.05	

Note

- The accuracy is measured at a constant temperature (normal temperature) under a constant load.
- Be sure to set the driver setting current to be less than the rated current of the actuator.
Exceeding the rated current of the actuator may damage the product.

① Maximum Holding Torque

This is the maximum holding torque the actuator has when power is supplied but the output table (hollow flange) is not rotating.

② Holding Torque at Motor Standstill

This is the holding torque when the automatic current cutback function is active.

③ Repetitive Positioning Accuracy

A value indicating the degree of error that generates when positioning is performed repeatedly to the same position in the same direction.

④ Permissible Axial Load

The permissible value of axial load applied to the output table (hollow flange) in the axial direction.

⑤ Permissible Moment Load

When a load is applied to a position away from the center of the output table (hollow flange), the output table (hollow flange) receives a tilting force. The permissible moment load refers to the permissible value of moment load calculated by multiplying the offset distance from the center by the applied load.

⑥ Runout of Output Table (Hollow Flange) Surface

The maximum value of runout of the mounting surface of the output table (hollow flange) when the output table (hollow flange) is rotated under no load.

⑦ Runout of Output Table (Hollow Flange) Inner/Outer Diameter

The maximum value of runout of the inner diameter or outer diameter of the table when the output table (hollow flange) is rotated under no load.

Specifications

Frame Size		28 mm	42 mm
Actuator Product Name		DHM28PAK2	DHM42PAK
Driver Product Name	Pulse Input RS-485 Communication	CVD507BR-K CVD5BR-KR	
Maximum Holding Torque	N·m	0.029	0.175
Holding Torque at Motor Standstill	Power ON N·m	0.014	0.087
Rotor Inertia	J : kg·m ²	3.5×10 ⁻⁶	25.5×10 ⁻⁶
Rated Current	A/Phase	0.75	
Basic Step Angle		0.72°	
Stop Position Accuracy		±0.33°	±0.11°
Repetitive Positioning Accuracy		±0.15°	±0.05°
Permissible Axial Load	N	40	150
Permissible Moment Load	N·m	0.1	0.4
Runout of Output Table (Hollow Flange) Surface	mm	0.05	
Runout of Output Table (Hollow Flange) Inner/Outer Diameter	mm	0.05	

Note

- The accuracy is measured at a constant temperature (normal temperature) under a constant load.
- Be sure to set the driver setting current to be less than the rated current of the actuator. Exceeding the rated current of the actuator may damage the product.

Speed - Torque Characteristics (Reference Value)

DHM28PAK2

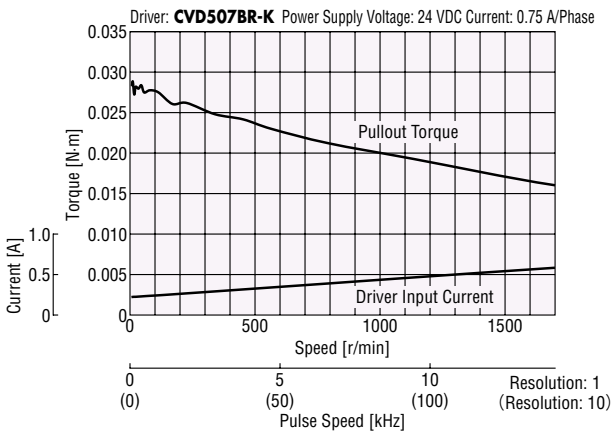

Note

- Data for the speed – torque characteristics is based on Oriental Motor's internal measurement conditions. If the conditions are changed, the characteristics may also change as a result.
- Depending on the driving conditions, a considerable amount of heat may be generated by the actuator. Be sure to keep the motor case temperature at 100°C max.
- The characteristics are the same when RS-485 communication type driver is used in combination.

DHM42PAK

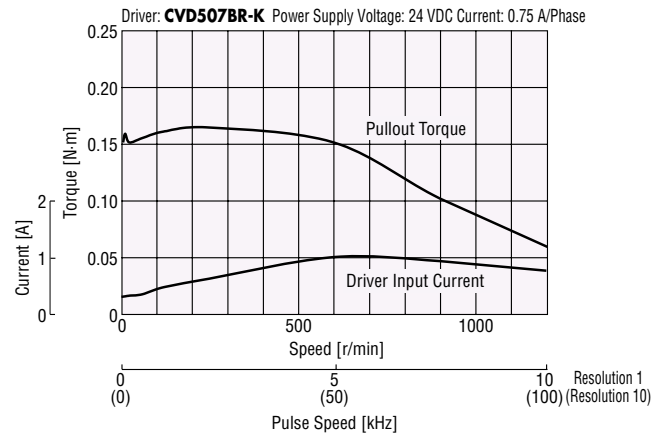

Operation Speed - Acceleration/Deceleration Rate (Reference Value)

DHM28PAK2

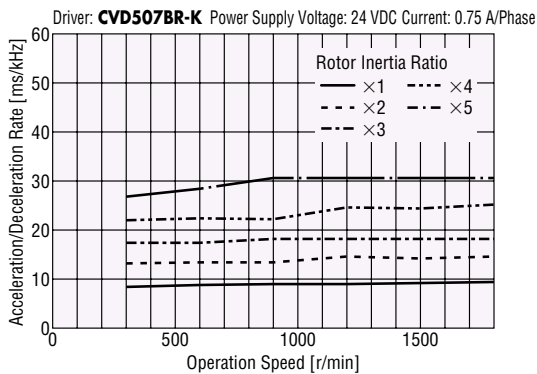

DHM42PAK

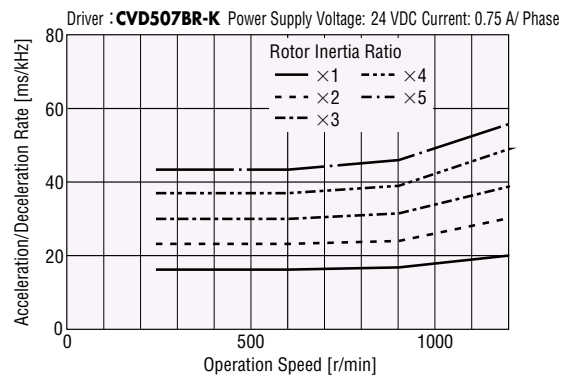

- These diagrams show the inertia ratio of the load inertia to the rotor inertia.

Drivers for 5-Phase Stepper Motors

CVD Series (Combination Driver)

The microstep function is equipped in the low-vibration design driver to enable even low-vibration and low-noise drive.

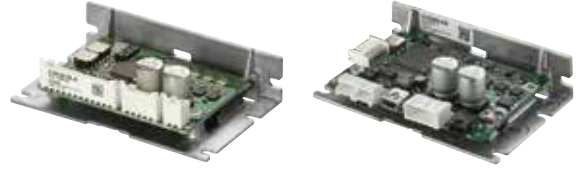

Product Number

Pulse Input Type

CVD 5 07 B R - K

① ② ③ ④ ⑤ ⑥

RS-485 Communication Type

CVD 5 B R - K R

① ② ③ ④ ⑤ ⑥

①	Series Name	CVD: CVD Series
②	5: 5-Phase	
③	Rated Current	
④	Driver Shape	B: With Installation Plate Blank: Without Installation Plate
⑤	Connector Shape	R: Right-Angle
⑥	Power Supply Input	K: DC Power Supply

①	Series Name	CVD: CVD Series
②	5: 5-Phase	
③	Driver Shape	B: With Installation Plate
④	Connector Shape	R: Right-Angle
⑤	Power Supply Input	K: DC Power Supply
⑥	Type	R: RS-485 Communication Type

Product Line

Pulse Input Type

◇ Right-Angle Type with Installation Plate

Product Name
CVD507BR-K

◇ With Installation Plate

Product Name
CVD507B-K

◇ Without Installation Plate

Product Name
CVD507-K

RS-485 Communication Type

◇ Right-Angle Type with Installation Plate

Product Name
CVD5BR-KR

◇ With Installation Plate

Product Name
CVD5B-KR

Included

Type	Connector for Driver Connection
Pulse Input Type	CN1 Connector (1 pc.) CN2 Connector (1 pc.) CN3 Connector (1 pc.)
RS-485 Communication Type	—

Specifications

Pulse Input Type

Product Name	CVD507BR-K	CVD507B-K	CVD507-K
Driving Method	Microstep Drive, Bipolar, Constant Current Drive Method		
Power Supply Voltage	24 VDC \pm 10%		
Input Current	A	1.4	
Max. Input Pulse Frequency	Line driver output by programmable controller: 1 MHz (When the pulse duty is 50%) Open-collector output by programmable controller: 250 kHz (When the pulse duty is 50%) Negative Logic Pulse Input		

RS-485 Communication Type

Product Name	CVD5BR-KR	CVD5B-KR
Driving Method	Microstep Drive, Bipolar, Constant Current Drive Method	
Power Supply Voltage	24 VDC \pm 10%	
Input Current	A	1.4
Interface	Control Input	7 points, Photocoupler
	Control Output	2 points, Photocoupler and Open Collector Output
	Field Network	Modbus RTU (RS-485 Communication)

RS-485 Communication Specifications

Electrical Characteristics	In compliance with EIA-485 Shielded twisted-pair wire is used up to a total extension length of 10 m.
Communication Mode	Half-duplex communication Synchronous mode (data: 8-bits, stop bit: 1-bit/2-bits, parity: none/odd/even)
Transmission Rate	Selected either from 9600 bps, 19200 bps, 38400 bps, 57600 bps, 115200 bps, or 230400 bps
Protocol	Modbus RTU Mode
Connection Type	Up to 31 units can be connected to one programmable controller (master equipment).

Dimensions (Unit: mm)

Pulse Input Type

Right-Angle Type with Installation Plate **2D & 3D CAD**

Product Name	Mass kg	2D CAD
CVD507BR-K	0.06	B1210

Included

Connector Housing:	51103-0200 (Molex)
	51103-0500 (Molex)
	51103-1200 (Molex)
Contact:	50351-8100 (Molex)

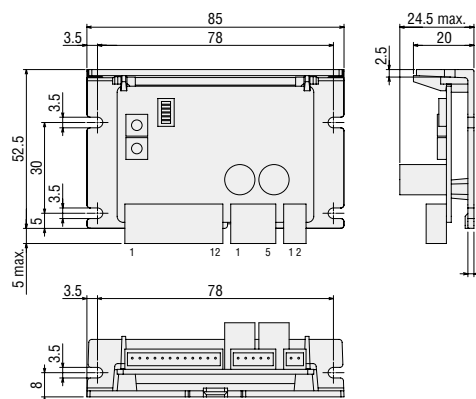

With Installation Plate

2D & 3D CAD

Product Name	Mass kg	2D CAD
CVD507B-K	0.06	B1255

Included

Connector Housing:	51103-0200 (Molex)
	51103-0500 (Molex)
	51103-1200 (Molex)
Contact:	50351-8100 (Molex)

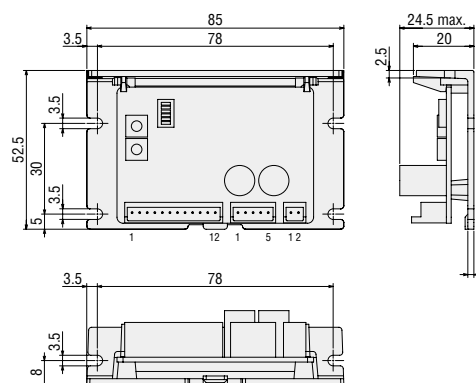

● Cables for motors (actuators), I/O signals, and DC power supply are available (sold separately).

Since the connector has already been crimped, no crimping tool is required and wiring can be done easily. Please see pages 8 and 15 to 17.

◇ Without Installation Plate

2D & 3D CAD

Product Name	Mass kg	2D CAD
CVD507-K	0.02	B1228

● Included

Connector Housing:	51103-0200 (Molex)	
	51103-0500 (Molex)	
	51103-1200 (Molex)	
Contact:	50351-8100 (Molex)	

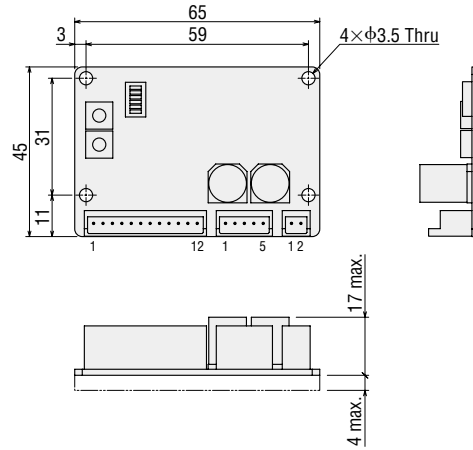

● Cables for motors (actuators), I/O signals, and DC power supply are available (sold separately).

Since the connector has already been crimped, no crimping tool is required and wiring can be done easily. Please see pages 8 and 15 to 17.

● RS-485 Communication Type

◇ Right-Angle Type with Installation Plate

2D & 3D CAD

Product Name	Mass kg	2D CAD
CVD5BR-KR	0.065	B1512

● Applicable Connector

Power Connector (CN1)

Connector Housing: 43645- 0200(Molex)
Contact: 43030- 0001(Molex)

Motor Connector (CN2)

Connector Housing: 51103- 0500(Molex)
Contact: 50351- 8100(Molex)

RS-485 Communication Connector (CN4, CN5)

Connector Housing: PAP-03V-S (J.S.T. Mfg. Co., Ltd.)
Contact: SPHD-001T-P0.5 or SPHD-002T-P0.5
(J.S.T. Mfg. Co., Ltd.)

I/O Signals Connector (CN6)

Connector Housing: PHDR-12VS (J.S.T. Mfg. Co., Ltd.)
Contact: SPHD-001T-P0. 5(J.S.T. Mfg. Co., Ltd.)

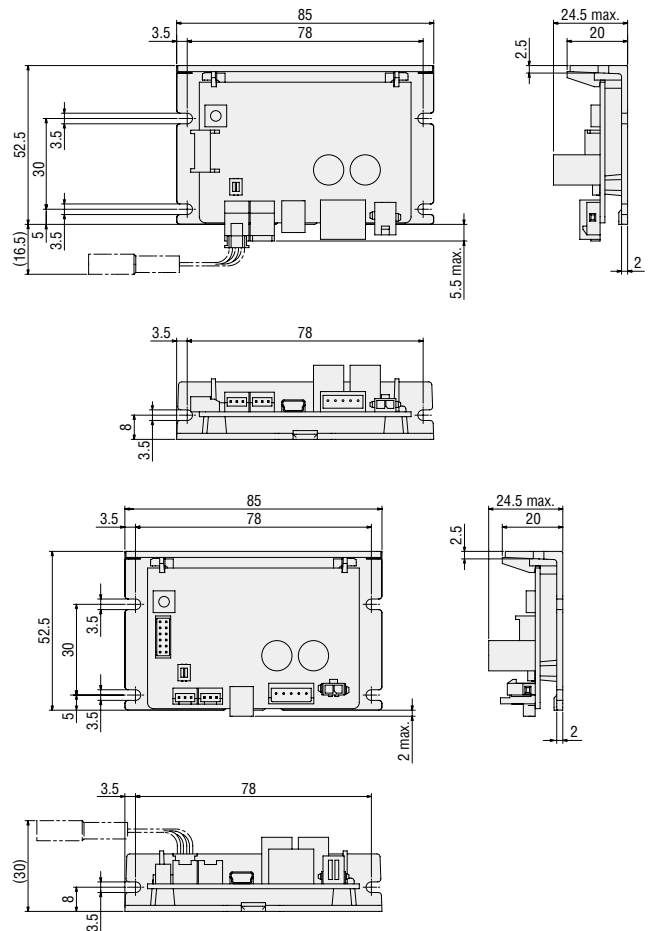

◇ With Installation Plate

2D & 3D CAD

Product Name	Mass kg	2D CAD
CVD5B-KR	0.065	B1511

● Applicable Connector

Power Connector (CN1)

Connector Housing: 43645- 0200(Molex)
Contact: 43030- 0001(Molex)

Motor Connector (CN2)

Connector Housing: 51103- 0500(Molex)
Contact: 50351- 8100(Molex)

RS-485 Communication Connector (CN4, CN5)

Connector Housing: PAP-03V-S (J.S.T. Mfg. Co., Ltd.)
Contact: SPHD-001T-P0.5 or SPHD-002T-P0.5
(J.S.T. Mfg. Co., Ltd.)

I/O Signals Connector (CN6)

Connector Housing: PHDR-12VS (J.S.T. Mfg. Co., Ltd.)
Contact: SPHD-001T-P0. 5(J.S.T. Mfg. Co., Ltd.)

● Cables for motors (actuators), power supply and I/O signals, and RS-485 communication are available (sold separately).

Since the connector has already been crimped, no crimping tool is required and wiring can be done easily. Please see pages 8 and 18.

Cables and Accessories

I/O Signal Cables (For Pulse Input Type)

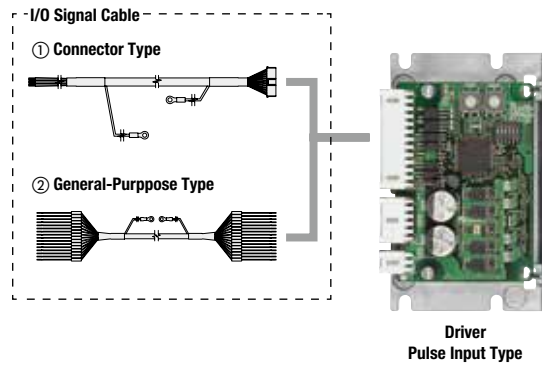

① Connector Type



These are connection cables between the host controller and the driver.

A shielded cable with protruding ground wires on both ends for easy grounding.

◇ Product Line

Product Name	Length L (m)	Conductor AWG
CC12D005-2	0.5	24 (0.2mm ²)
CC12D010-2	1	
CC12D015-2	1.5	
CC12D020-2	2	

● For dimensions please visit our website.

② General-Purpose Type



These are connection cables between the host controller and the driver. Both ends are flying lead wires.

A shielded cable with protruding ground wires on both ends for easy grounding.

◇ Product Line

Product Name	Length L (m)	Number of Lead Wire Cores	Outer Diameter D (mm)	AWG
CC06D005B-1	0.5	6	φ5.4	24 (0.2mm ²)
CC06D010B-1	1			
CC06D015B-1	1.5			
CC06D020B-1	2			
CC10D005B-1	0.5	10	φ6.7	
CC10D010B-1	1			
CC10D015B-1	1.5			
CC10D020B-1	2			
CC12D005B-1	0.5	12	φ7.5	
CC12D010B-1	1			
CC12D015B-1	1.5			
CC12D020B-1	2			

● For dimensions please visit our website.

DC Power Supply Cables (For Pulse Input Type)

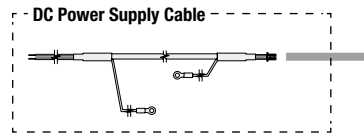

Driver
Pulse Input Type



◇ Product Line

Product Name	Length L (m)	Conductor AWG
CC02D005-2	0.5	22 (0.3mm ²)
CC02D010-2	1	
CC02D015-2	1.5	
CC02D020-2	2	

● For dimensions please visit our website.

These cables are used to connect the driver and the DC power supply.

A shielded cable with protruding ground wires on both ends for easy grounding.

Connection Cable Sets for Driver (For Pulse Input Type)

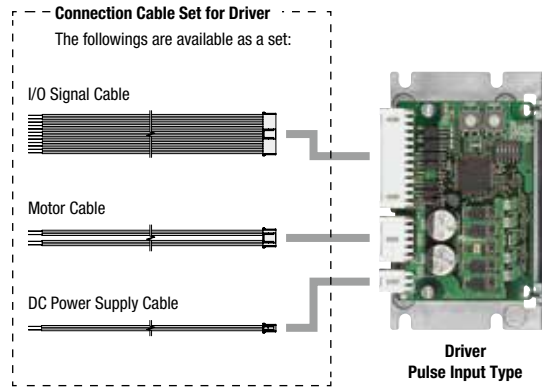

Connecting Cables for motor (actuator), I/O signals, and DC power supply that can be connected to the driver are available as a set. A connector is coupled on the driver side of each cable.

Product Line



Product Name	Connector	Connector Name	Length L1	Length L2	Conductor AWG
LCS04SD5	For Motor	51103-0500	0.6 m	10 mm	22 (0.3 mm ²)
	For Power Supply	51103-0200			
	For I/O Signal	51103-1200			

Connector Pin Assignments

◇ For Motor

Pin No.	Wire Color
1	Blue
2	Red
3	Orange
4	Green
5	Black

◇ For Power Supply

Pin No.	Wire Color
1	Red
2	Black

◇ For I/O Signal

Pin No.	Wire Color
1	Brown
2	Red
3	Orange
4	Yellow
5	Green
6	Blue
7	Purple
8	Gray
9	White
10	Black
11	Brown
12	Red

Dimensions

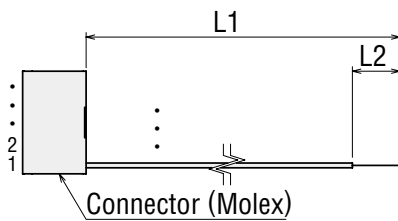

Connection Cable without Termination Processing



These cables are used to extend the connection between motor (actuator) and driver. The wiring distance between the motor (actuator) and the driver should be 10 m or less.

Product Line

Product Name	Cable Type	Length L (m)	Conductor AWG	Finished Outer Diameter (mm)
CC05PK5	Connection Cables	5	For Motor: 22 (0.3 mm ²)	φ7.2
CC10PK5		10		
CC05PK5R	Flexible Connection Cables	5	For Motor: 22 (0.3 mm ²)	φ5.8
CC10PK5R		10		

- Cable Core Structure Motor: 5
- Cable Rating: 105°C
- Cable Sheath: Oil-resistant, heat-resistant, non-transferable vinyl
- For dimensions please visit our website.

Power Supply Cable and I/O Signal Cable Sets (For RS-485 Communication Type)

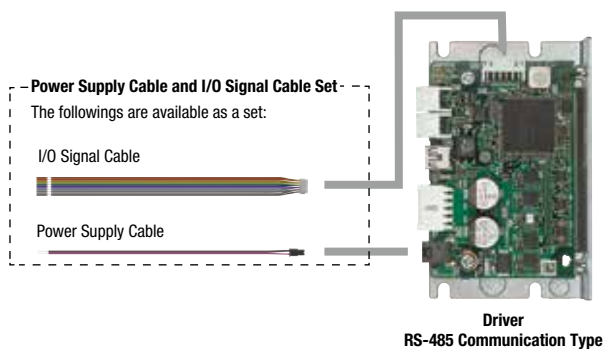

Power supply cable connects the driver and the DC power supply.

I/O signal cable connects the drivers and the host controller.

Power supply cable and I/O signal cable are available as a set.

Product Line

Product Name	Length L (m)
LHS003CC	0.3
LHS010CC	1

Dimensions (Unit: mm)

Power Supply Cable

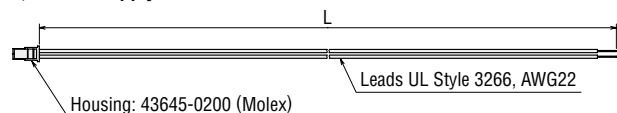

I/O Signal Cable

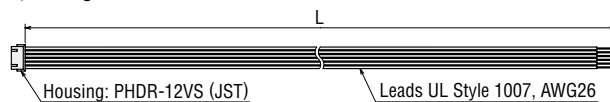

RS-485 Communication Cables (For RS-485 Communication Type)

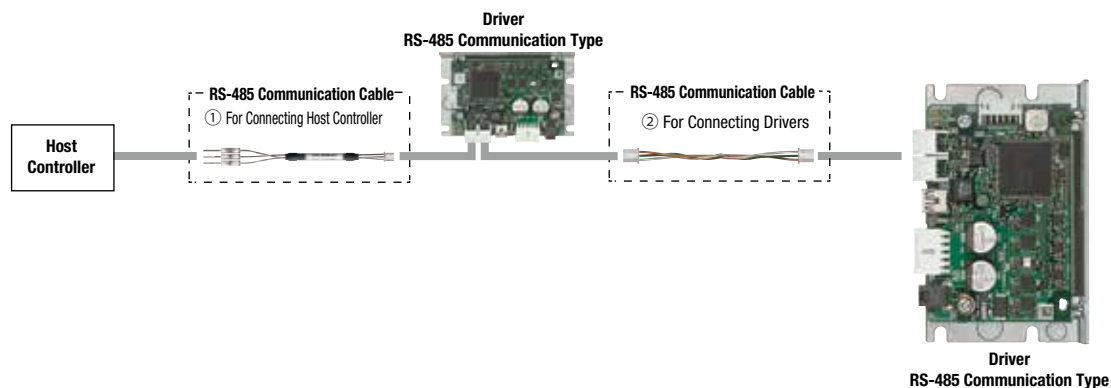

① For connecting host controller

This cable is used to connect the driver and the host controller

Product Line

Product Name	Length L (m)
CC030-RS	3

Dimensions (Unit: mm)

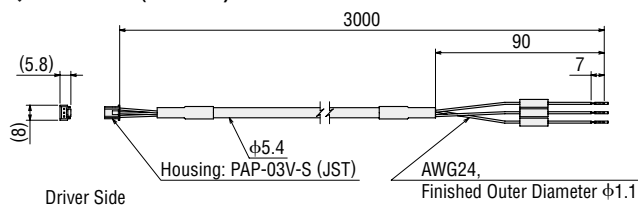

② For connecting drivers

This cable is used to connect two drivers together.

Product Line

Product Name	Length L (m)
LH0015-RWN	0.15

Dimensions (Unit: mm)

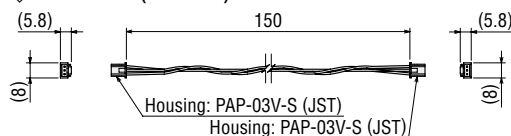

Driver Mounting Bracket

This is bracket for installation on a DIN rail.



Driver Cover

This is a protection cover to prevent contact with the circuit board. Available for the right angle type driver with an installation plate.



<Application Example>

Note

● Cannot be attached to RS-485 communication type drivers.

Product Line

Product Name	Applicable Drivers	Surface Treatment
MADP07	CVD5□□BR-K CVD5□□B-K CVD5BR-KR CVD5B-KR	Electroless nickel plating

Product Line

Product Name	Applicable Drivers
PADC-CVD	CVD5□□BR-K

Oriental Motor Asia Pacific Pte. Ltd.

2 Kaki Bukit Ave 1 #05-06
Singapore 417818
TEL: +65-6745-7344 FAX: +65-6745-9405
<http://www.orientalmotor.com.sg/>

Oriental Motor (Thailand) Co., Ltd.

Headquarters & Bangkok Office
63 Athenee Tower, 6th Floor Unit 603, Wireless Rd,
Lumpini, Pathumwan, Bangkok 10330, Thailand
TEL: +66-2-251-1871 FAX: +66-2-251-1872
<http://www.orientalmotor.co.th/>

Oriental Motor (India) Pvt. Ltd.

No.810, 8th Floor, Prestige Meridian-1 No.29,
M.G.Road, Bangalore, 560001, India
TEL: +91-80-41125586 FAX: +91-80-41125588
<http://www.orientalmotor.co.in/>

Oriental Motor (Malaysia) Sdn. Bhd.

Headquarters & Kuala Lumpur office
A-13-1, North Point Offices, Mid Valley City,
No.1 Medan Syed Putra Utara 59200
Kuala Lumpur, Malaysia
TEL: +60-3-22875778 FAX: +60-3-22875528

Penang office
1-4-14 Krystal Point II, Lebuh Bukit Kecil 6,
Bayan Lepas 11900 Penang, Malaysia
TEL: +60-4-6423788 FAX: +60-4-6425788
<http://www.orientalmotor.com.my/>