

RoHS RoHS-Compliant

Unit Type Speed Control Motor and Control Unit Package

US Series

Single-Phase 110/115 VAC, Single-Phase 220/230 VAC



US Series

Single-Phase 110/115 VAC, Single-Phase 220/230 VAC



The **US** Series is a panel mounted control unit and speed control motor package, which complies with the RoHS directive. Wiring is performed by connecting with an easy-to-use one-touch connectors. This series is perfect for easy speed control applications.

● Instantaneous stop function is not equipped.



Features

● Easy Connection

The operation is possible just by connecting the control unit into the power supply after connecting the motor and control unit through one-touch connector.

● Easy Operation

The speed can be set easily with the potentiometer on the front panel of the control unit.

● Approved by Safety Standards

The US Series is recognized by UL/CSA standards and certified under CCC System. CE marking is used in accordance with the low voltage directive and EMC directive.

● Long Life, Low Noise **GN-S** Gearhead is available.

(Applicable Motors: 6 W~40 W)

The newly marketed "Long Life, Low Noise **GN-S** Gearhead" realizes a rated life time of 10000 hours, which is twice the life time of conventional products, through new technology and a new construction.

Gearhead noise has also been reduced.

● Protective Earth Terminal on Motor (6 W~40 W)

● **RoHS** RoHS-Compliant

The **US** Series conforms to the RoHS Directive, which prohibits the use of 6 chemical substances including lead and cadmium.

RoHS (Restriction of Hazardous Substances) Directive:
 Directive on restriction of the use of certain hazardous substances in electrical and electronic equipment (2002/95/EC).
 The RoHS Directive prohibits the use of six chemical substances in electrical and electronic products sold in the E.U. member countries.
 The six controlled substances are: lead, hexavalent chromium, cadmium, mercury and two specific brominated flame-retardants (PBB and PBDE).

Safety Standards and CE Marking

	Standards	Certification Body	Standards File No.	CE Marking
Motor	UL 1004 UL 2111	UL	E64199 (6 W) E64197 (15 W~90 W)	Low Voltage Directives EMC Directives
	CSA C22.2 No.100 CSA C22.2 No.77			
	EN 60034-1 EN 60034-5 EN 60950-1 IEC 60664-1	Conform to EN/IEC Standards		
	GB12350	CQC	2003010401091525 (6 W) 2003010401091522 (15 W~90 W)	
Control Unit	UL 508	UL	E91291	
	CSA C22.2 No.14			
	EN 50178 EN 60950-1	Conform to EN Standards		

● When the system is approved under various safety standards, the model names in the motor and speed control unit nameplates are the approved model names.

List of Motor and Speed Control Unit Combinations → page 15

● The EMC value changes according to the wiring and layout. Therefore, the final EMC level must be checked with the break pack incorporated in the user's equipment.

System Configuration

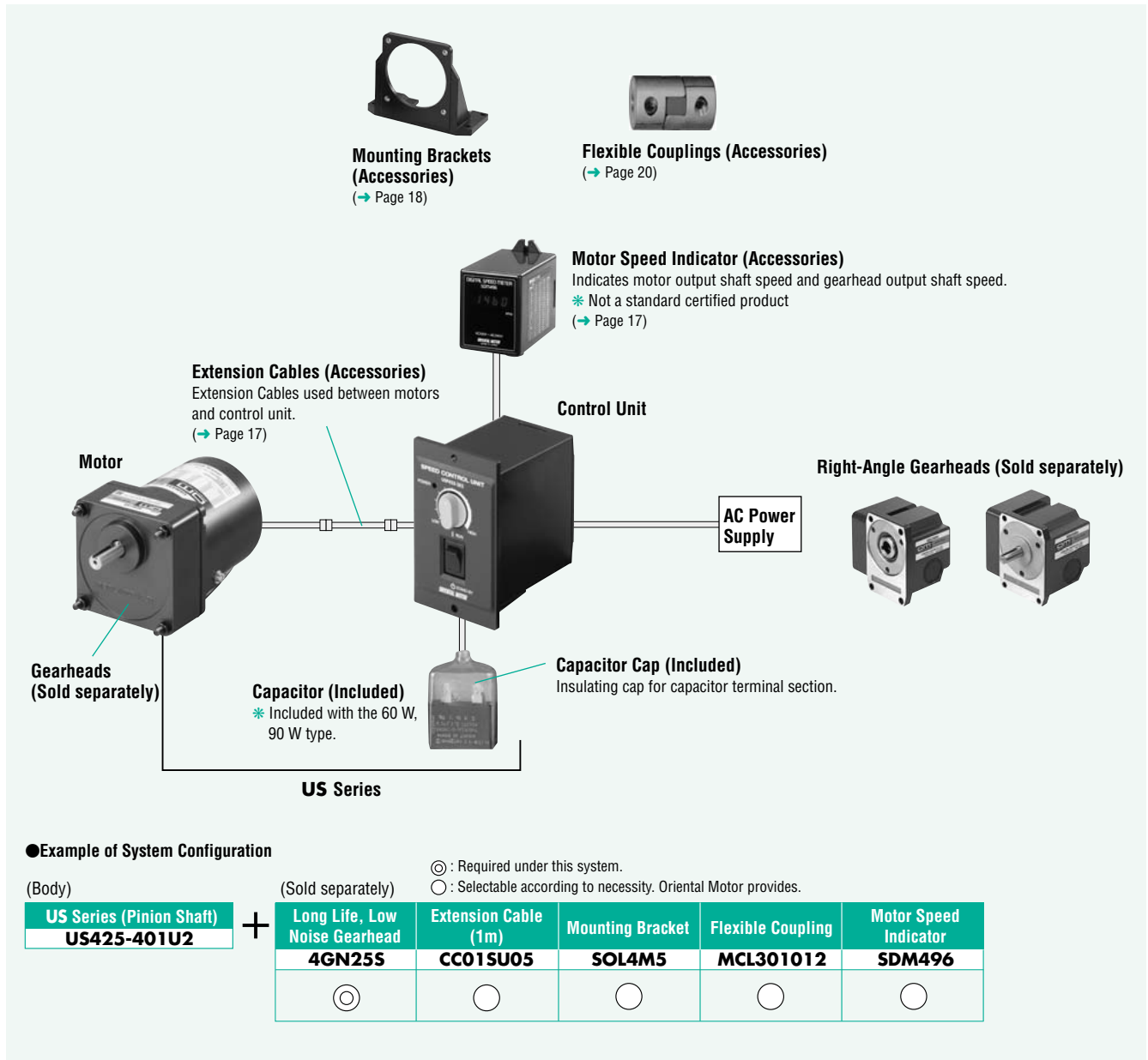

● The system configuration shown above is an example. Other configurations are available.

Product Number Code

US Series

US 5 40 - 4 0 2E 2

① ② ③ ④ ⑤ ⑥ ⑦

①	Series	US: US Series
②	Motor Frame Size	2: 60 mm 3: 70 mm 4: 80 mm 5: 90 mm
③	Output Power (W)	(Example) 40: 40 W
④	Motor Shaft Type, Type of Pinion	0: Round Shaft 4: GN Type Pinion Shaft 5: GU Type Pinion Shaft
⑤	Motor Type	0: Induction Motor
⑥	Power Supply Voltage	1U: Single-Phase 110/115 VAC 2E: Single-Phase 220/230 VAC
⑦		2: RoHS-Compliant

Gearhead

5 GN 50 S

① ② ③ ④

①	Gearhead Frame Size	2: 60 mm 3: 70 mm 4: 80 mm 5: 90 mm
②	Type of Pinion	GN: GN Type Pinion GU: GU Type Pinion
③	Gear Ratio	(Example) 50: Gear Ratio of 1: 50 10X denotes the decimal gearhead of gear ratio 1:10
④	GN Type Pinion	S: Long Life, Low Noise GN-S Gearhead, RoHS-Compliant RH: Right-Angle, Hollow Shaft Gearhead, RoHS-Compliant RA: Right-Angle, Solid Shaft Gearhead, RoHS-Compliant
④	GU Type Pinion	KB: GU Gearhead (Box Type), RoHS-Compliant K: GU Gearhead (Flange Mounting Type), RoHS-Compliant RH: Right-Angle, Hollow Shaft Gearhead, RoHS-Compliant RA: Right-Angle, Solid Shaft Gearhead, RoHS-Compliant

Product Line

US Series (RoHS)

Output Power	Power Supply Voltage	Model	
		Pinion Shaft Type	Round Shaft Type
6 W	Single-Phase 110/115 VAC	US206-401U2	US206-001U2
	Single-Phase 220/230 VAC	US206-402E2	US206-002E2
15 W	Single-Phase 110/115 VAC	US315-401U2	US315-001U2
	Single-Phase 220/230 VAC	US315-402E2	US315-002E2
25 W	Single-Phase 110/115 VAC	US425-401U2	US425-001U2
	Single-Phase 220/230 VAC	US425-402E2	US425-002E2
40 W	Single-Phase 110/115 VAC	US540-401U2	US540-001U2
	Single-Phase 220/230 VAC	US540-402E2	US540-002E2
60 W	Single-Phase 110/115 VAC	US560-501U2	US560-001U2
	Single-Phase 220/230 VAC	US560-502E2	US560-002E2
90 W	Single-Phase 110/115 VAC	US590-501U2	US590-001U2
	Single-Phase 220/230 VAC	US590-502E2	US590-002E2

Parallel Shaft Gearheads (Sold Separately)

◇ Long Life, Low Noise **GN-S** Gearhead (RoHS)

Applicable Motor Output Power (Pinion Shaft)	Gearhead Model	Gear Ratio
6 W	2GN□S	3~180
	2GN10XS (Decimal gearhead)	
15 W	3GN□S	3~180
	3GN10XS (Decimal gearhead)	
25 W	4GN□S	3~180
	4GN10XS (Decimal gearhead)	
40 W	5GN□S	3~180
	5GN10XS (Decimal gearhead)	

● Enter the gear ratio in the box (□) within the model name.

◇ **GU** Gearhead (RoHS)

Applicable Motor Output Power (Pinion Shaft)	Gearhead Model	Gear Ratio
60 W 90 W	5GU□KB 5GU□K	3~180
	5GU10XKB, 5GU10XK (Decimal gearhead)	

● Enter the gear ratio in the box (□) within the model name.

Right-Angle Gearhead (Sold separately) (RoHS)

◇ Hollow Shaft (RoHS)

Applicable Motor Output Power (Pinion Shaft)	Gearhead Model	Gear Ratio
25 W	4GN□RH	3~180
40 W	5GN□RH	3~180
60 W 90 W	5GU□RH	3~180

● Enter the gear ratio in the box (□) within the model name.

◇ Solid Shaft Type (RoHS)

Applicable Motor Output Power (Pinion Shaft)	Gearhead Model	Gear Ratio
25 W	4GN□RA	3~180
40 W	5GN□RA	3~180
60 W 90 W	5GU□RA	3~180

● Enter the gear ratio in the box (□) within the model name.

Model		Max. Output Power	Voltage	Frequency	Variable Speed Range*	Permissible Torque		Starting Torque	Current	Power Consumption			
						1200 r/min	90 r/min						
Pinion Shaft Type	Round Shaft Type	W	VAC	Hz	r/min	mN·m	mN·m	mN·m	A	W			
Ⓢ US206-401U2	US206-001U2	6	Single-Phase 110	60	90~1600	50	37	40	0.28	28			
			Single-Phase 115										
Ⓢ US206-402E2	US206-002E2	6	Single-Phase 220	50	90~1400	44	40	38	0.13	28			
			Single-Phase 115	60	90~1600	50	39	40					
			Single-Phase 230	50	90~1400	47	38	40					
			Single-Phase 115	60	90~1600	50	37						
Ⓢ US315-401U2	US315-001U2	15	Single-Phase 110	60	90~1600	125	45	55	0.47	44			
			Single-Phase 115						0.50				
Ⓢ US315-402E2	US315-002E2	15	Single-Phase 220	50	90~1400	125	35	54	0.21	40			
			Single-Phase 115	60	90~1600	85		52	0.18	39			
			Single-Phase 230	50	90~1400	125		54	0.21	41			
			Single-Phase 115	60	90~1600	105		55	0.22	44			
Ⓢ US425-401U2	US425-001U2	25	Single-Phase 110	60	90~1600	200	50	105	0.74	70			
			Single-Phase 115							73			
Ⓢ US425-402E2	US425-002E2	25	Single-Phase 220	50	90~1400	205	40	100	0.36	68			
			Single-Phase 115	60	90~1600	160			0.37				
			Single-Phase 230	50	90~1400	205	40	110	0.35				
			Single-Phase 115	60	90~1600	140	35	0.36					
Ⓢ US540-401U2	US540-001U2	40	Single-Phase 110	60	90~1600	260	70	180	1.1	102			
			Single-Phase 115							105			
Ⓢ US540-402E2	US540-002E2	40	Single-Phase 220	50	90~1400	300	63	140	0.53	90			
			Single-Phase 115	60	90~1600	230		125	0.55	98			
			Single-Phase 230	50	90~1400	300		140	0.53	90			
			Single-Phase 115	60	90~1600	230		140	0.55	100			
Ⓢ US560-501U2	US560-001U2	60	Single-Phase 110	60	90~1600	490	200	285	2.0	178			
			Single-Phase 115						2.1	186			
Ⓢ US560-502E2	US560-002E2	60	Single-Phase 220	50	90~1400	490	140	240	0.85	154			
			Single-Phase 115	60	90~1600	450	160	210	0.86	159			
			Single-Phase 230	50	90~1400	490	140	240	0.89	154			
			Single-Phase 115	60	90~1600	450	160	240	0.88	165			
Ⓢ US590-501U2	US590-001U2	90	Single-Phase 110	60	90~1600	730	200	405	2.6	230			
			Single-Phase 115							246			
Ⓢ US590-502E2	US590-002E2	90	Single-Phase 220	50	90~1400	730	230	360	1.1	200			
			Single-Phase 115	60	90~1600					260	360	221	
			Single-Phase 230	50	90~1400					230	400	1.2	201
			Single-Phase 115	60	90~1600					260	400	227	

* The variable speed ranges shown are under no load conditions.

Ⓢ: Impedance protected

Ⓢ: Contains a built-in thermal protector (automatic return type). If a motor overheats for any reason, the thermal protector is activated and the motor is stopped. When the motor temperature drops, the thermal protector closes and the motor restarts. Be sure to turn the motor off before inspecting.

General Specifications

Item	Motor	Control Unit
Insulation Resistance	100 MΩ or more when 500 VDC megger is applied between the windings and the motor case after rated operation under normal ambient temperature and humidity.	100 MΩ or more when 500 VDC megger is applied between all the pins and frame after rated operation under normal ambient temperature and humidity.
Dielectric Strength	Sufficient to withstand 1.5 kV at 50 Hz or 60 Hz applied between the windings and the frame for 1 minute after rated motor operation under normal ambient temperature and humidity.	Sufficient to withstand 2.3 kV (3.0 kV for single-phase 220/230 VAC) at 60 Hz applied between all the pins and the frame for 1 minute after rated motor operation under normal ambient temperature and humidity.
Temperature Rise	Temperature rise of windings are 80°C or less measured by the resistance change method after rated motor operation under normal ambient temperature and humidity, with connecting a gearhead or equivalent heat radiation plate* to a motor.	—
Overheat Protection	US206 type has impedance protection. All others have built-in thermal protector (automatic return type) open: 130±5°C, close: 82±15°C	—
Operating Environment	Ambient Temperature	0~+40°C (non-freezing)
	Ambient Humidity	85% or less (non-condensing)
	Altitude	Up to 1000 m above sea level
Insulation Class	Class B (130°C)	—
Degree of Protection	US206, US315, US425 and US540 types: IP20 US560 and US590 types: IP40	IP10

*Heat radiation plate (Material: Aluminum)

Type (Output)	Size (mm)	Thickness (mm)
US206 type (6 W)	115×115	5
US315 type (15 W)	125×125	
US425 type (25 W)	135×135	
US540 type (40 W)	165×165	
US560 type (60 W)	200×200	
US590 type (90 W)	200×200	

Variable Speed Range when Gearhead is Attached

Unit = r/min

Gear Ratio	3	3.6	5	6	7.5	9	12.5	15	18	25	30	36	50	60	75	90	100	120	150	180	
High Speed	50 Hz	466	388	280	233	186	155	112	93	77	56	46	38	28	23	18	15	14	11	9	7
	60 Hz	533	444	320	266	213	177	128	106	88	64	53	44	32	26	21	17	16	13	10	8.8
Low Speed	30	25	18	15	12	10	7.2	6	5	3.6	3	2.5	1.8	1.5	1.2	1	0.9	0.75	0.6	0.5	

Gearmotor – Torque Table

- Gearheads and decimal gearheads are sold separately.
- Enter the gear ratio in the box (□) within the model name.
- A colored background (□) indicates gear shaft rotation in the same direction as the motor shaft, while the others rotate in the opposite direction.
- To reduce the speed beyond the gear ratio in the table, attach a decimal gearhead (gear ratio: 10) between the gearhead and the motor.
In that case, the permissible torques are as follows.

2GN□S: 3 N·m **3GN□S**: 5 N·m

4GN□S: 8 N·m (when a gearhead of 1/25~1/36 is connected, the value for permissible torque is 6 N·m)

5GN□S: 10 N·m **5GU□KB, 5GU□K**: 20 N·m

Single-Phase 110/115 VAC

Unit = N·m

Model Motor/ Gearhead	Gear Ratio Motor Speed r/min	3	3.6	5	6	7.5	9	12.5	15	18	25	30	36	50	60	75	90	100	120	150	180
		US206-401U2 /2GN□S	1200	0.12	0.15	0.20	0.24	0.30	0.36	0.51	0.61	0.73	0.91	1.1	1.3	1.7	2.0	2.5	3	3	3
	90	0.09	0.11	0.15	0.18	0.22	0.27	0.37	0.45	0.54	0.68	0.81	0.97	1.2	1.5	1.8	2.2	2.4	2.9	3	3
US315-401U2 /3GN□S	1200	0.30	0.36	0.51	0.61	0.76	0.91	1.3	1.5	1.8	2.3	2.7	3.3	4.1	5	5	5	5	5	5	5
	90	0.11	0.13	0.18	0.22	0.27	0.33	0.46	0.55	0.66	0.82	0.99	1.2	1.5	1.8	2.2	2.7	3.0	3.6	4.5	5
US425-401U2 /4GN□S	1200	0.49	0.58	0.81	0.97	1.2	1.5	2.0	2.4	2.9	3.7	4.4	5.3	6.6	7.9	8	8	8	8	8	8
	90	0.12	0.15	0.20	0.24	0.30	0.36	0.51	0.61	0.73	0.91	1.1	1.3	1.7	2.0	2.5	3.0	3.3	4.0	5.0	5.9
US540-401U2 /5GN□S	1200	0.63	0.76	1.1	1.3	1.6	1.9	2.6	3.2	3.8	4.7	5.7	6.8	8.6	10	10	10	10	10	10	10
	90	0.17	0.20	0.28	0.34	0.43	0.51	0.71	0.85	1.0	1.3	1.5	1.8	2.3	2.8	3.5	4.2	4.6	5.5	6.9	8.3
US560-501U2 /5GU□KB, 5GU□K	1200	1.2	1.4	2.0	2.4	3.0	3.6	4.5	5.4	6.4	8.1	9.7	11.6	16.2	19.4	20	20	20	20	20	20
	90	0.49	0.58	0.81	0.97	1.2	1.5	1.8	2.2	2.6	3.3	4.0	4.8	6.6	7.9	8.9	10.6	11.8	14.2	17.7	20
US590-501U2 /5GU□KB, 5GU□K	1200	1.8	2.1	3.0	3.5	4.4	5.3	6.7	8.0	9.6	12.0	14.5	17.3	20	20	20	20	20	20	20	20
	90	0.49	0.58	0.81	0.97	1.2	1.5	1.8	2.2	2.6	3.3	4.0	4.8	6.6	7.9	8.9	10.6	11.8	14.2	17.7	20

● Single-Phase 220/230 VAC

Unit = N·m

Model Motor/ Gearhead	Gear Ratio		3	3.6	5	6	7.5	9	12.5	15	18	25	30	36	50	60	75	90	100	120	150	180
	Motor Speed r/min																					
US206-402E2 /2GN□S	1200	220/230 VAC 60 Hz	0.12	0.15	0.20	0.24	0.30	0.36	0.51	0.61	0.73	0.91	1.1	1.3	1.7	2.0	2.5	3	3	3	3	3
		220 VAC 50 Hz	0.11	0.13	0.18	0.21	0.27	0.32	0.45	0.53	0.64	0.80	0.96	1.2	1.5	1.7	2.2	2.6	2.9	3	3	3
		230 VAC 50 Hz	0.11	0.14	0.19	0.23	0.29	0.34	0.48	0.57	0.69	0.86	1.0	1.2	1.6	1.9	2.3	2.8	3	3	3	3
	90	220 VAC 60 Hz	0.095	0.11	0.16	0.19	0.24	0.28	0.39	0.47	0.57	0.71	0.85	1.0	1.3	1.5	1.9	2.3	2.6	3	3	3
		230 VAC 60 Hz	0.09	0.11	0.15	0.18	0.22	0.27	0.37	0.45	0.54	0.68	0.81	0.97	1.2	1.5	1.8	2.2	2.4	2.9	3	3
		220 VAC 50 Hz	0.097	0.12	0.16	0.19	0.24	0.29	0.41	0.49	0.58	0.73	0.88	1.1	1.3	1.6	2.0	2.4	2.6	3	3	3
		230 VAC 50 Hz	0.092	0.11	0.15	0.18	0.23	0.28	0.38	0.46	0.55	0.69	0.83	1.0	1.3	1.5	1.9	2.3	2.5	3	3	3
US315-402E2 /3GN□S	1200	220 VAC 60 Hz	0.21	0.25	0.34	0.41	0.52	0.62	0.86	1.0	1.2	1.6	1.9	2.2	2.8	3.4	4.2	5	5	5	5	5
		220/230 VAC 50 Hz	0.30	0.36	0.51	0.61	0.76	0.91	1.3	1.5	1.8	2.3	2.7	3.3	4.1	5	5	5	5	5	5	5
		230 VAC 60 Hz	0.26	0.31	0.43	0.51	0.64	0.77	1.1	1.3	1.5	1.9	2.3	2.8	3.5	4.2	5	5	5	5	5	5
			90	0.085	0.10	0.14	0.17	0.21	0.26	0.35	0.43	0.51	0.64	0.77	0.92	1.2	1.4	1.7	2.1	2.3	2.8	3.5
US425-402E2 /4GN□S	1200	220 VAC 60 Hz	0.39	0.47	0.65	0.78	0.97	1.2	1.6	1.9	2.3	2.9	3.5	4.2	5.3	6.3	7.9	8	8	8	8	8
		230 VAC 60 Hz	0.34	0.41	0.57	0.68	0.85	1.0	1.4	1.7	2.0	2.6	3.1	3.7	4.6	5.5	6.9	8	8	8	8	8
		220/230 VAC 50 Hz	0.50	0.60	0.83	1.0	1.2	1.5	2.1	2.5	3.0	3.7	4.5	5.4	6.8	8	8	8	8	8	8	8
	90	220 VAC 50/60 Hz 230 VAC 50 Hz	0.097	0.12	0.16	0.19	0.24	0.29	0.41	0.49	0.58	0.73	0.88	1.1	1.3	1.6	2.0	2.4	2.6	3.2	4.0	4.8
		230 VAC 60 Hz	0.085	0.10	0.14	0.17	0.21	0.26	0.35	0.43	0.51	0.64	0.77	0.92	1.2	1.4	1.7	2.1	2.3	2.8	3.5	4.2
US540-402E2 /5GN□S	1200	220/230 VAC 60 Hz	0.56	0.67	0.93	1.1	1.4	1.7	2.3	2.8	3.4	4.2	5.0	6.0	7.6	9.1	10	10	10	10	10	10
		220/230 VAC 50 Hz	0.73	0.87	1.2	1.5	1.8	2.2	3.0	3.6	4.4	5.5	6.6	7.9	9.9	10	10	10	10	10	10	10
		90	0.15	0.18	0.26	0.31	0.38	0.46	0.64	0.77	0.92	1.1	1.4	1.7	2.1	2.5	3.1	3.7	4.2	5.0	6.2	7.5
US560-502E2 /5GU□KB, 5GU□K	1200	220/230 VAC 60 Hz	1.1	1.3	1.8	2.2	2.7	3.3	4.1	4.9	5.9	7.4	8.9	10.7	14.9	17.8	19.9	20	20	20	20	20
		220/230 VAC 50 Hz	1.2	1.4	2.0	2.4	3.0	3.6	4.5	5.4	6.4	8.1	9.7	11.6	16.2	19.4	20	20	20	20	20	20
	90	220/230 VAC 60 Hz	0.39	0.47	0.65	0.78	0.97	1.2	1.5	1.8	2.1	2.6	3.2	3.8	5.3	6.3	7.1	8.5	9.4	11.3	14.2	17.0
		220/230 VAC 50 Hz	0.34	0.41	0.57	0.68	0.85	1.0	1.3	1.5	1.8	2.3	2.8	3.3	4.6	5.5	6.2	7.4	8.3	9.9	12.4	14.9
US590-502E2 /5GU□KB, 5GU□K	1200		1.8	2.1	3.0	3.5	4.4	5.3	6.7	8.0	9.6	12.0	14.5	17.3	20	20	20	20	20	20	20	
	90	220/230 VAC 60 Hz	0.63	0.76	1.1	1.3	1.6	1.9	2.4	2.8	3.4	4.3	5.1	6.2	8.6	10.3	11.5	13.8	15.3	18.4	20	20
		220/230 VAC 50 Hz	0.56	0.67	0.93	1.1	1.4	1.7	2.1	2.5	3.0	3.8	4.6	5.5	7.6	9.1	10.2	12.2	13.6	16.3	20	20

■ Permissible Overhung Load and Permissible Thrust Load

Motor (Round shaft type) → Page 16

Gearhead → Page 16

■ Permissible Load Inertia of Gearhead: J

→ Page 16

■ Speed – Torque Characteristics

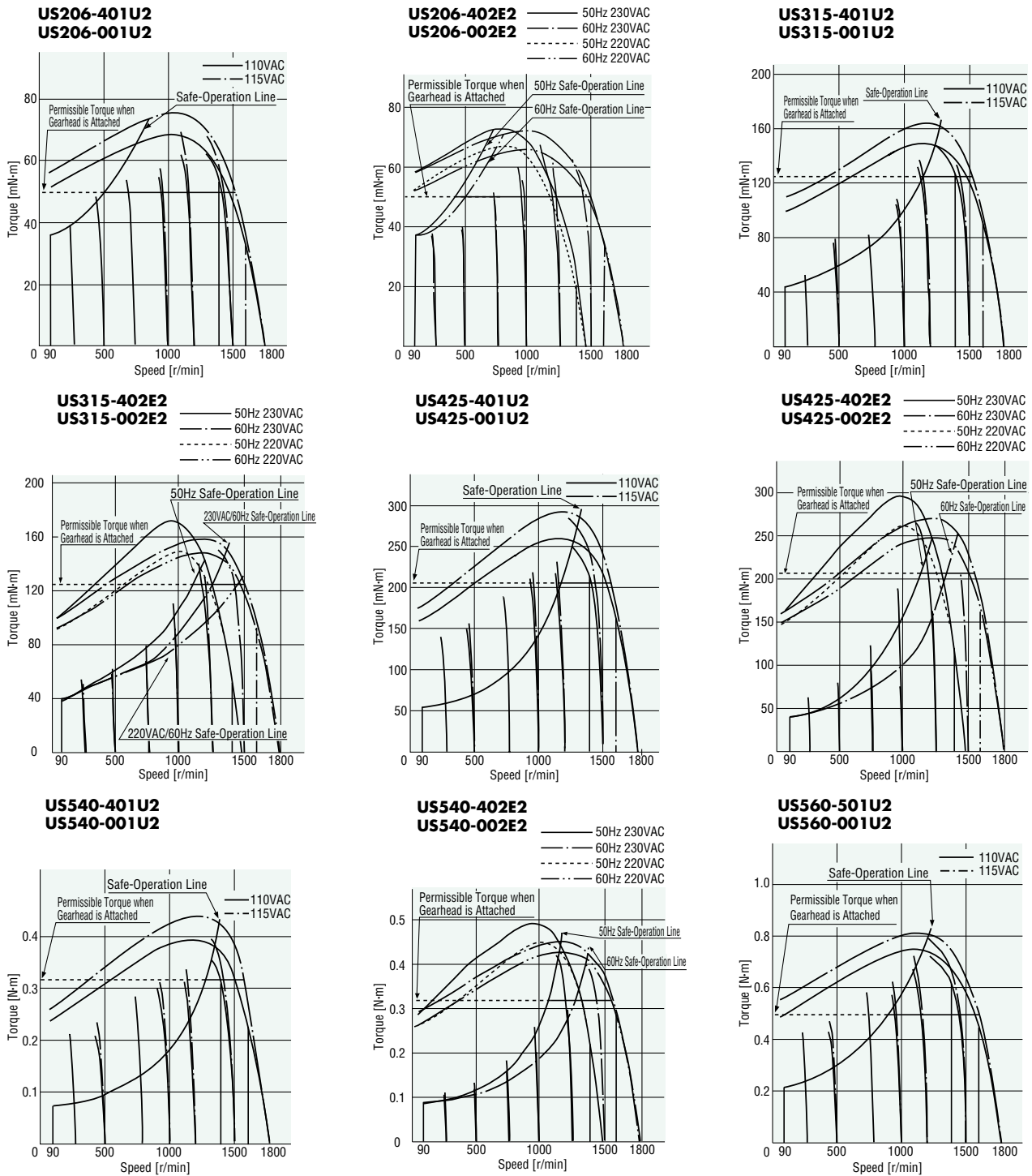

**US560-502E2
US560-002E2**

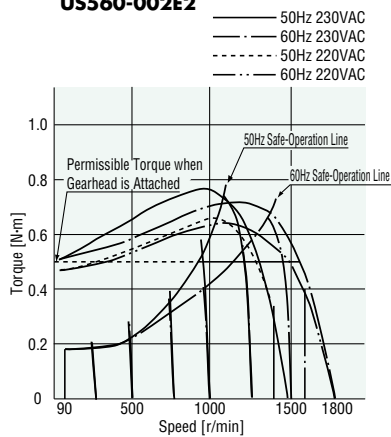

**US590-501U2
US590-001U2**

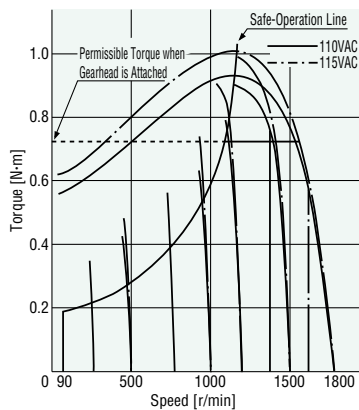

**US590-502E2
US590-002E2**

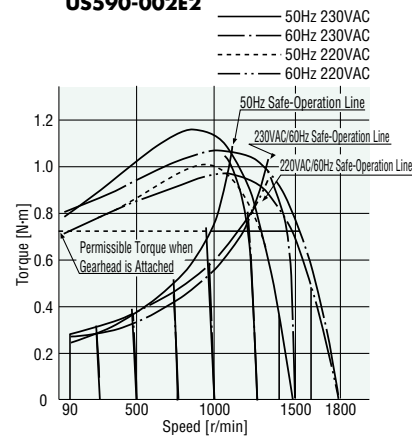

Dimensions (Unit = mm)

Mounting screws are included with gearheads.

● 6 W

◇ Motor/Gearhead

Model	Motor Model	Gearhead Model	Gear Ratio	L1	CAD
US206-401U2	USM206-401W2	2GN□S	3~18	30	A486A
US206-402E2	USM206-402W2		25~180	40	A486B

Mass: Motor 0.8kg

Gearhead 0.4kg

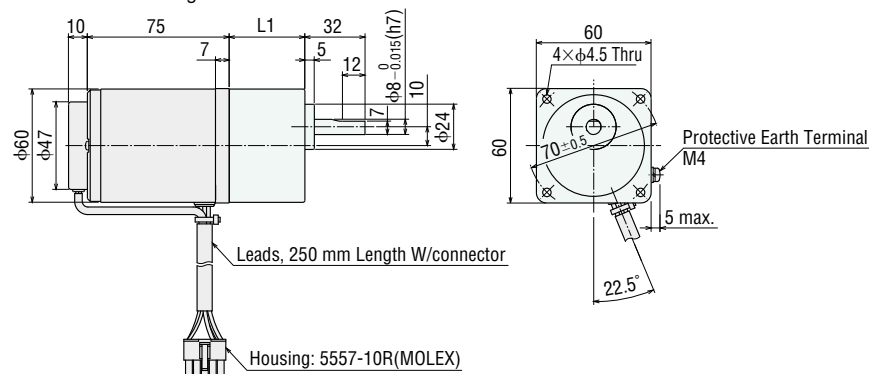

◇ Shaft Section of Round Shaft Type

The motor's dimensions (excluding the shaft section) are the same as those of the pinion shaft type.

US206-001U2, US206-002E2

Motor: USM206-001W2, USM206-002W2

Mass: 0.8 kg

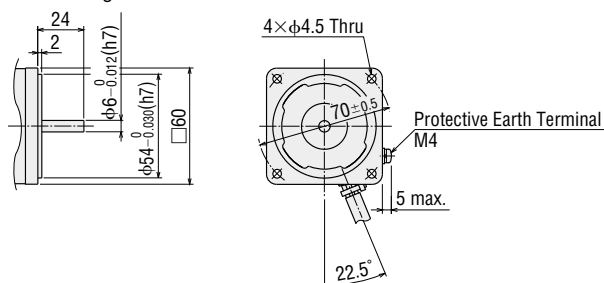

◇ Decimal Gearhead

Can be connected to **US206** pinion shaft type.

2GN10XS

Mass: 0.2 kg

CAD A003

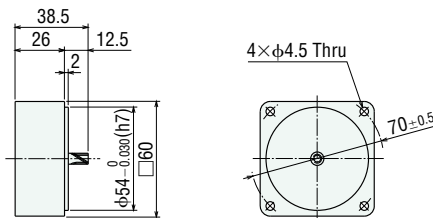

● Enter the gear ratio in the box (□) within the model name.

● 15 W

◇ Motor/Gearhead

Model	Motor Model	Gearhead Model	Gear Ratio	L1	CAD
US315-401U2 US315-402E2	USM315-401W2 USM315-402W2	3GN□S	3~18 25~180	32 42	A488A A488B

Mass: Motor 1.2 kg
Gearhead 0.55 kg

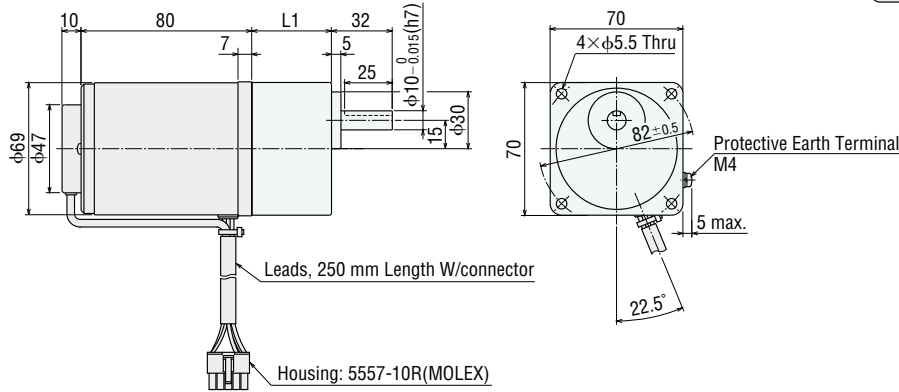

◇ Key and Key Slot

(The key is included with the gearhead)

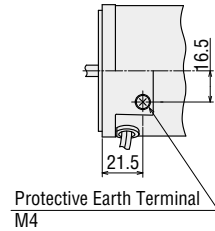
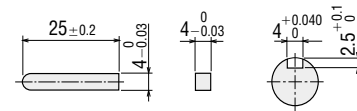

Detail Drawing of Protective Earth Terminal

◇ Shaft Section of Round Shaft Type

The motor's dimensions (excluding the shaft section) are the same as those of the pinion shaft type.

US315-001U2, US315-002E2

Motor: USM315-001W2, USM315-002W2

Mass: 1.2 kg

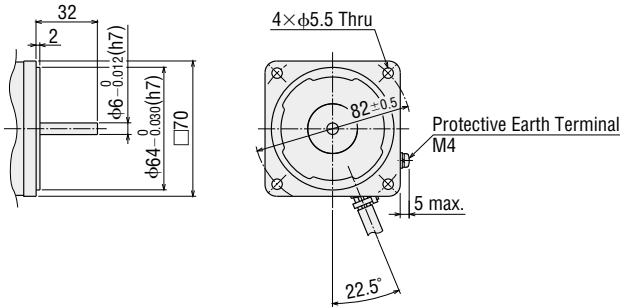

◇ Decimal Gearhead

Can be connected to **US315** pinion shaft type.

3GN10XS

Mass: 0.3 kg

CAD A009

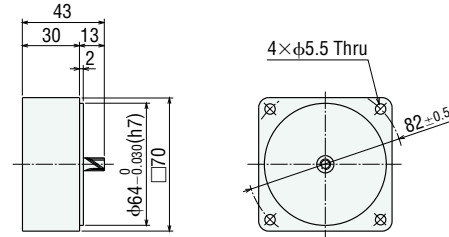

● 25 W

◇ Motor/Gearhead

Model	Motor Model	Gearhead Model	Gear Ratio	L1	CAD
US425-401U2 US425-402E2	USM425-401W2 USM425-402W2	4GN□S	3~18 25~180	32 42.5	A490A A490B

Mass: Motor 1.6 kg
Gearhead 0.65 kg

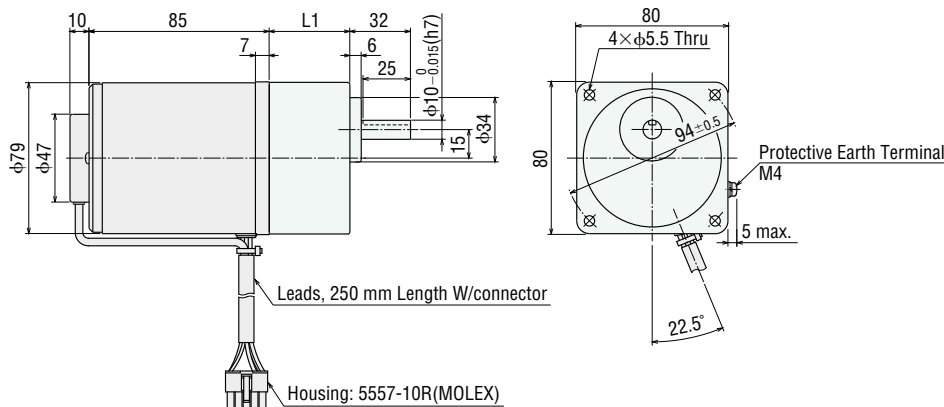

◇ Key and Key Slot

(The key is included with the gearhead)

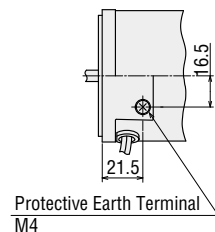
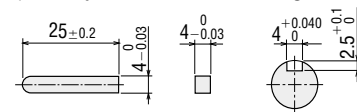

Detail Drawing of Protective Earth Terminal

● Enter the gear ratio in the box (□) within the model name.

◇ Shaft Section of Round Shaft Type

The motor's dimensions (excluding the shaft section) are the same as those of the pinion shaft type.

US425-001U2, US425-002E2

Motor: USM425-001W2, USM425-002W2

Mass: 1.6 kg

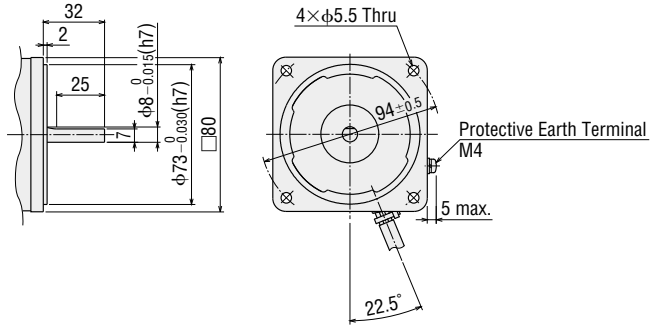

◇ Decimal Gearhead

Can be connected to **US425** pinion shaft type.

4GN10XS

Mass: 0.4 kg

CAD A013

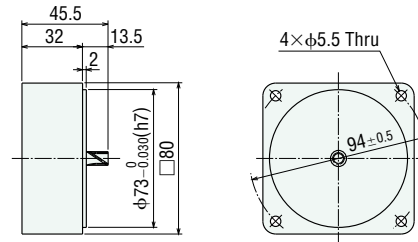

● 40 W

◇ Motor/Gearhead

Model	Motor Model	Gearhead Model	Gear Ratio	L1	CAD
US540-401U2	USM540-401W2	5GN□S	3~18	42	A492A
US540-402E2	USM540-402W2		25~180	60	A492B

Mass: Motor 2.6 kg

Gearhead 1.5 kg

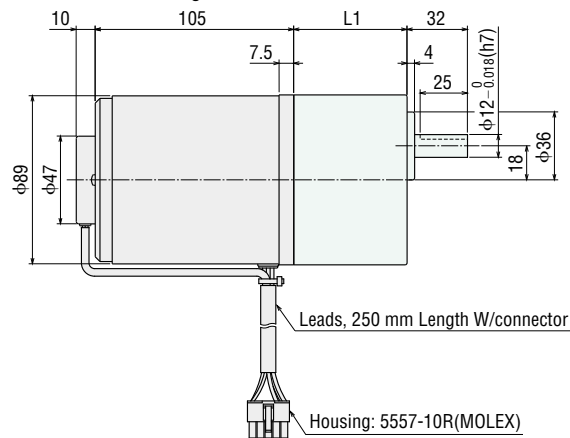

◇ Key and Key Slot

(The key is included with the gearhead)

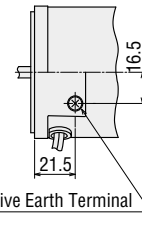
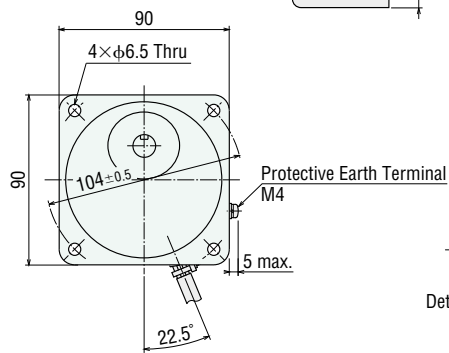
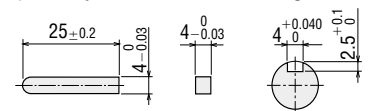

Detail Drawing of Protective Earth Terminal

◇ Shaft Section of Round Shaft Type

The motor's dimensions (excluding the shaft section) are the same as those of the pinion shaft type.

US540-001U2, US540-002E2

Motor: USM540-001W2, USM540-002W2

Mass: 2.6 kg

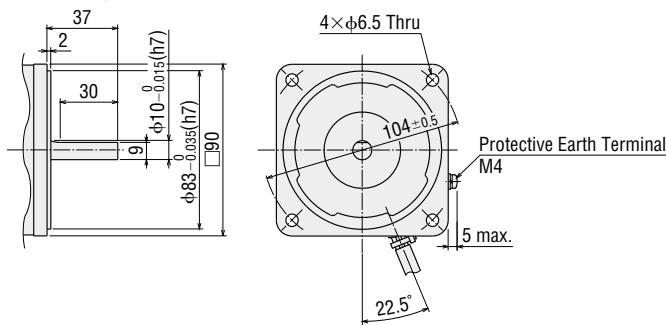

◇ Decimal Gearhead

Can be connected to **US540** pinion shaft type.

5GN10XS

Mass: 0.6 kg

CAD A022

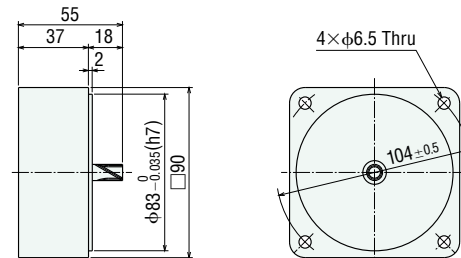

● Enter the gear ratio in the box (□) within the model name.

● 60 W

◇ Motor/Gearhead

Model	Motor Model	Gearhead Model	L1	CAD
US560-501U2 US560-502E2	USM560-501W-1 USM560-502W-1	5GU□KB	150	A494

Mass: Motor 2.8 kg
Gearhead 1.5 kg

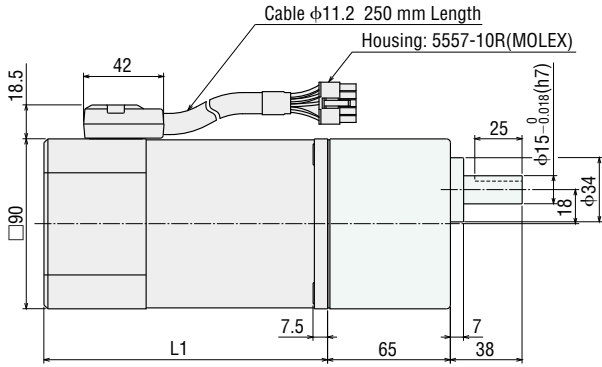

● 90 W

◇ Motor/Gearhead

Model	Motor Model	Gearhead Model	L1	CAD
US590-501U2 US590-502E2	USM590-501W-1 USM590-502W-1	5GU□KB	165	A496

Mass: Motor 3.6 kg
Gearhead 1.5 kg

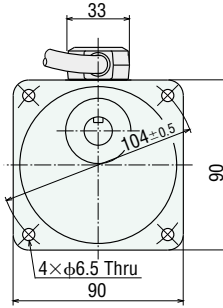

◇ Key and Key Slot

(The key is included with the gearhead)
common to **5GU□KB** and **5GU□K**

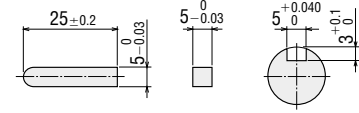

◇ Shaft Section of Round Shaft Type

The motor's dimensions (excluding the shaft section) are the same as those of the pinion shaft type.

US560-001U2, US560-002E2

Motor: USM560-001W-1, USM560-002W-1
Mass: 2.8 kg

US590-001U2, US590-002E2

Motor: USM590-001W-1, USM590-002W-1
Mass: 3.6 kg

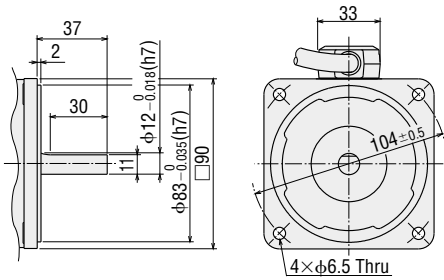

◇ Decimal Gearhead

Can be connected to **US560** or **US590** pinion shaft type.

5GU10XKB (for **5GU□KB**), **5GU10XK** (for **5GU□K**)

Mass: 0.6kg

CAD A029

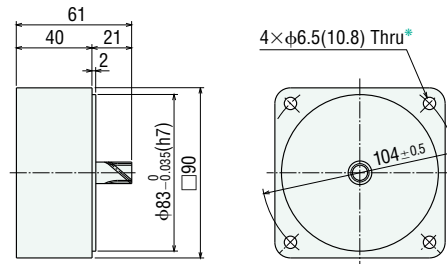

* The figure in parenthesis indicates the dimension of **5GU10XKB**.

◇ Flange Mounting Type Gearhead

Can be connected to **US560** or **US590** pinion shaft type.

5GU□K

Mass: 1.5 kg

CAD A030

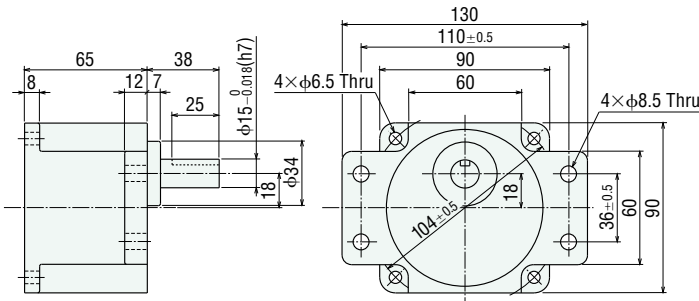

◇ Control Unit

Common to **US206**, **US315**, **US425** and **US540** Type

USP206-1U2/USP206-2E2

USP315-1U2/USP315-2E2

USP425-1U2/USP425-2E2

USP540-1U2/USP540-2E2

Mass: 0.45 kg

CAD A498

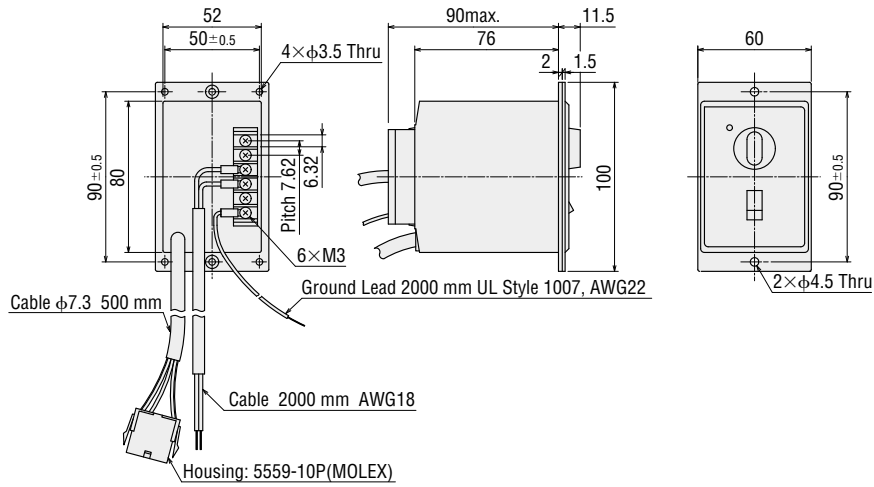

Common to **US560** and **US590** Type

USP560-1U2/USP560-2E2

USP590-1U2/USP590-2E2

Mass: 0.5 kg

CAD A499

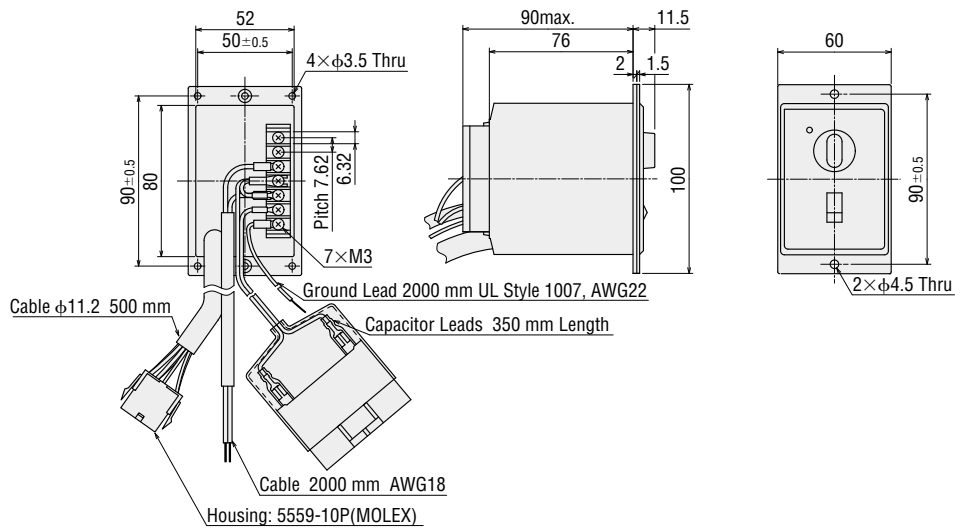

◇ Panel Cut-Out for Control Unit

Installation Method by Cutting a Square Hole

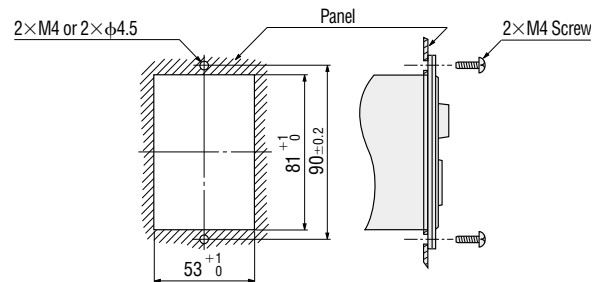

◇ Capacitor (Included)

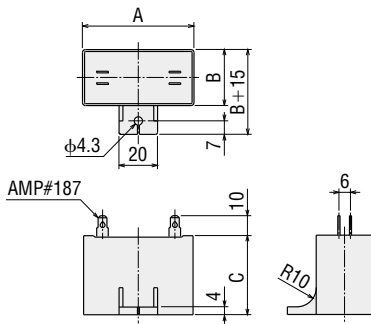

◇ Capacitor Dimensions (mm)

Model		Capacitor Model	A	B	C	Mass (g)
Pinion Shaft Type	Round Shaft Type					
US560-501U2	US560-001U2	CH180CFAUL2	58	29	41	95
US560-502E2	US560-002E2	CH40BFAUL	58	23.5	37	70
US590-501U2	US590-001U2	CH200CFAUL2	58	29	41	95
US590-502E2	US590-002E2	CH60BFAUL	58	29	41	85

● A capacitor cap is included with a capacitor.

■ Connection and Operation

● Names and Functions of Control Unit Parts

Control Unit Front Panel

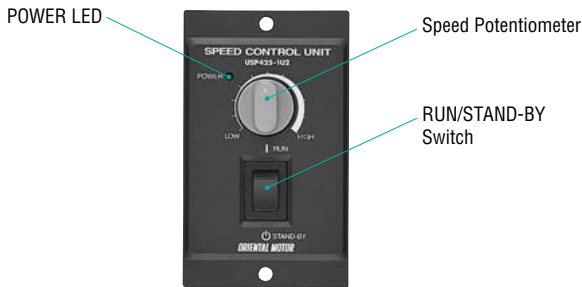

● Connection Diagrams

◇ US206, US315, US425 and US540 types

Continuous Rotation:

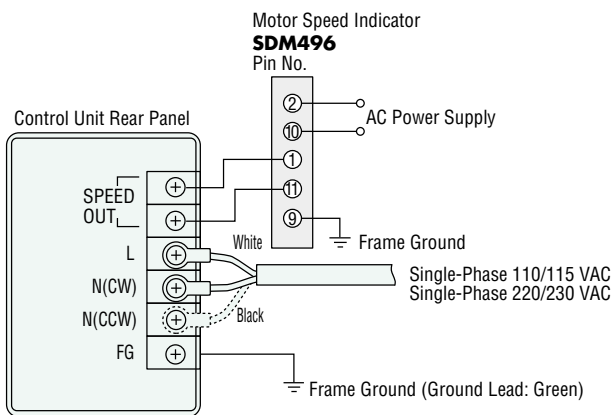

● In the diagrams above, the motor shaft rotates in the clockwise direction.
When changed to the dotted line [N (CCW)] position, the motor shaft rotates in the counterclockwise direction.

Bi-directional Rotation:

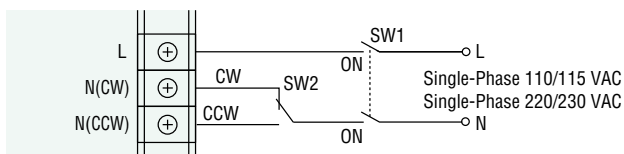

Specifications
250 VAC 5 A min. (Induction load)

◇ US560 and US590 types

Continuous Rotation:

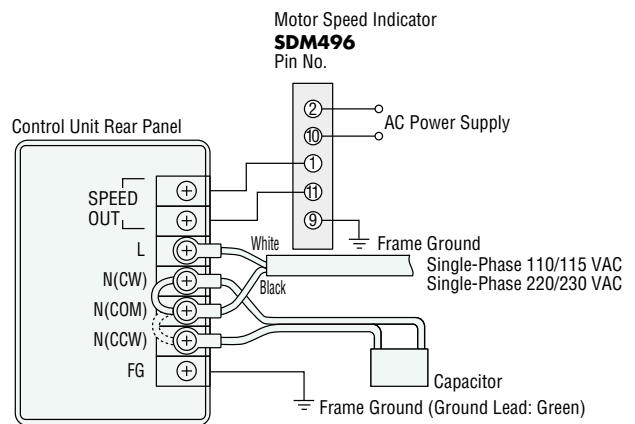

● In the diagrams above, the motor shaft rotates in the clockwise direction.
When changed to the dotted line [N (CCW)] position, the motor shaft rotates in the counterclockwise direction.

Bi-directional Rotation:

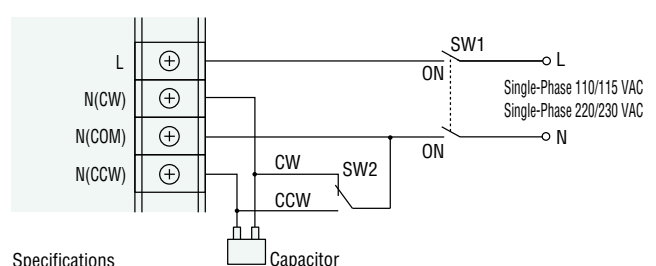

Specifications
250 VAC 5 A min. (Induction load)

● Operation Method

There is a difference in operation method between the **US206, US315, US425, US540** types and the **US560, US590** types.

◇ Rotation

Connect the motor lead wire connectors to the control unit. Then connect the power cord (2 m, AWG18) to the power supply. When the RUN/STAND-BY switch of the control unit is switched to RUN, the motor rotates in the clockwise (CW) direction as seen from the motor shaft. Control units are set for clockwise rotation at shipment. The direction of rotation for the gearhead output shaft may be the reverse of the direction of the motor shaft depending on the gear ratio.

◇ Changing Speed

When the potentiometer located on the front of the control unit is turned in a clockwise direction, motor speed increases; when turned in the counterclockwise direction, motor speed decreases. Motor speed can be set and adjusted over a range of 90 r/min~1400 r/min at 50 Hz, 90 r/min~1600 r/min at 60 Hz.

◇ Stopping

When the RUN/STAND-BY switch on the control unit is set to STAND-BY, the motor stops. This switch is not a power ON/OFF switch. If the motor is to be stopped for a long time, a separate power ON/OFF switch should be installed.

◇ Switching the Direction of Rotation

● **US206, US315, US425 and US540** types
(Capacitor is included in the control unit.)

Uni-directional Rotation:

When the direction of motor rotation needs to be reversed for reasons relating to transmission mechanisms such as gearheads, change the terminal used for attaching the power cord, located at the back of control unit, from terminal N (CW) to terminal N (CCW). The power cord connections are located at terminals L and N (CW) when shipped. This should always be done with the power OFF.

Bi-directional Rotation:

Install an additional power switch (SW1) and CW/CCW switch (SW2) as shown on page 14, and use these switches to change the direction of rotation. Motor cannot be reversed instantaneously. Turn SW1 off and wait until the motor has come to a complete stop before switching SW2.

● **US560 and US590** types

(Connection of the included capacitor is necessary.)

Uni-directional Rotation:

When the direction of motor rotation needs to be reversed, change the terminal used for attaching the power cord, located at the back of control unit, from terminals N (CW)-N (COM) to terminals N (COM)-N (CCW). The power cord connections are located at terminals N(CW)-N(COM) when shipped. This should always be done with the power OFF.

Bi-directional Rotation:

Install an additional power switch (SW1) and CW/CCW switch (SW2) as shown on page 14, and use these switches to change the direction of rotation. Motor cannot be reversed instantaneously. Turn SW1 off and wait until the motor has come to a complete stop before switching SW2.

■ List of Motor and Control Unit Combinations

Model name for motor and control unit combinations are shown below.

● Single-Phase 110/115 VAC

Output Power	Model	Motor Model	Control Unit
6 W	US206-401U2	USM206-401W2	USP206-1U2
	US206-001U2	USM206-001W2	
15 W	US315-401U2	USM315-401W2	USP315-1U2
	US315-001U2	USM315-001W2	
25 W	US425-401U2	USM425-401W2	USP425-1U2
	US425-001U2	USM425-001W2	
40 W	US540-401U2	USM540-401W2	USP540-1U2
	US540-001U2	USM540-001W2	
60 W	US560-501U2	USM560-501W-1	USP560-1U2
	US560-001U2	USM560-001W-1	
90 W	US590-501U2	USM590-501W-1	USP590-1U2
	US590-001U2	USM590-001W-1	

● Single-Phase 220/230 VAC

Output Power	Model	Motor Model	Control Unit
6 W	US206-402E2	USM206-402W2	USP206-2E2
	US206-002E2	USM206-002W2	
15 W	US315-402E2	USM315-402W2	USP315-2E2
	US315-002E2	USM315-002W2	
25 W	US425-402E2	USM425-402W2	USP425-2E2
	US425-002E2	USM425-002W2	
40 W	US540-402E2	USM540-402W2	USP540-2E2
	US540-002E2	USM540-002W2	
60 W	US560-502E2	USM560-502W-1	USP560-2E2
	US560-002E2	USM560-002W-1	
90 W	US590-502E2	USM590-502W-1	USP590-2E2
	US590-002E2	USM590-002W-1	

Common Specifications

■ Permissible Overhung Load and Permissible Thrust Load of Motors

● Permissible Overhung Load

Motor		Permissible Overhung Load N	
Motor Frame Size □ (mm)	Output Shaft Diameter φ (mm)	Distance from Shaft End	
		10 mm	20 mm
60	6	50	110
70	6	40	60
80	8	90	140
90	10	140	200
	12	240	270

● Permissible Thrust Load

Avoid thrust loads as much as possible. If thrust load is unavoidable, keep it to half or less of the motor mass.

■ Permissible Overhung Load and Permissible Thrust Load of Gearheads

Model	Gear Ratio	Max. Permissible Torque N·m	Permissible Overhung Load N		Permissible Thrust Load N
			10 mm from Shaft End	20 mm from Shaft End	
2GN □S	3~18	3.0	50	80	30
	25~180		120	180	
3GN □S	3~18	5.0	80	120	40
	25~180		150	250	
4GN □S	3~18	8.0	100	150	50
	25~180		200	300	
5GN □S	3~18	10	250	350	100
	25~180		300	450	
5GU □KB 5GU □K	3~9	20	400	500	150
	12.5~18		450	600	
	25~180		500	700	

■ Permissible Load Inertia of Gearhead: J

When a high load inertia (J) is connected to a gearhead, high torque is exerted instantaneously on the gearhead when starting up in frequent, discontinuous operations (or when stopped instantaneously). Excessive impact loads can cause the gearhead or motor damage.

The table below gives values for permissible load inertia on the motor shaft. Use the motor and gearhead within these parameters. The permissible load inertia (J) on the gearhead output shaft is calculated with the following equation.

The life of the gearhead when operating at the permissible inertial load with instantaneous stops of the motors with speed control motors is at least 2 million cycles.

● Permissible Load Inertia at the Gearhead Output Shaft

$$\begin{aligned} \text{Gear Ratio } 1/3 \sim 1/50 & \quad J_G = J_M \times i^2 & \quad J_G : \text{Permissible load inertia at the motor shaft } J (\times 10^{-4} \text{kg}\cdot\text{m}^2) \\ \text{Gear Ratio } 1/60 \text{ or higher} & \quad J_G = J_M \times 2500 & \quad J_M : \text{Permissible load inertia at the motor shaft } J (\times 10^{-4} \text{kg}\cdot\text{m}^2) \\ & & \quad i : \text{Gear Ratio (Example: } i=3 \text{ means the gear ratio of } 1/3) \end{aligned}$$

● Permissible Load Inertia at the Motor Shaft

No. of Phase	Motor Frame Size	Output Power	Permissible Load Inertia at the Motor Shaft J ($\times 10^{-4} \text{kg}\cdot\text{m}^2$)
Single-Phase	□60 mm	6 W	0.062
	□70 mm	15 W	0.14
	□80 mm	25 W	0.31
	□90 mm	40 W	0.75
		60 W	1.1
		90 W	1.1

Accessories

Extension Cables RoHS

Extension cable for connecting **US** series motor and speed control unit. Two types are available, depending on the motor output power. The maximum extension length is 4.75 m.

Applicable Motors

◇ **US206, US315, US425** and **US540** types (110/115 VAC, 220/230 VAC)

Model	Cable Length: L(m)
CC01SU05	1
CC02SU05	2
CC03SU05	3
CC04SU05	4

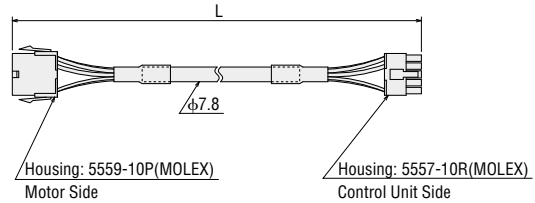

Applicable Motors

◇ **US560** and **US590** types (110/115 VAC, 220/230 VAC)

Model	Cable Length: L(m)
CC01SU07	1
CC02SU07	2
CC03SU07	3
CC04SU07	4

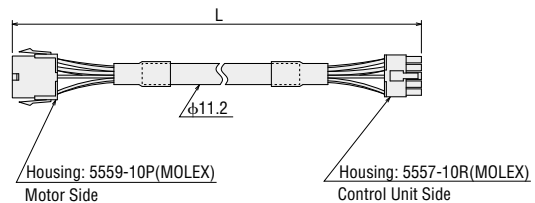

Digital Display Type Motor Speed Indicator RoHS

● Model: **SDM496** (Single-Phase 100 VAC~240 VAC)



This product is a digital speed indicator that directly displays the speed at the output shaft of the motor or gearhead. **SDM496** is not approved by any safety standards.

Included with **SDM496**

To mount in a panel, a flush mounting adapter **EPUA-31** and round shape socket **EP11MS** are provided with the speed indicator.

Dimensions (Unit = mm)

Mass: 200 g CAD A100

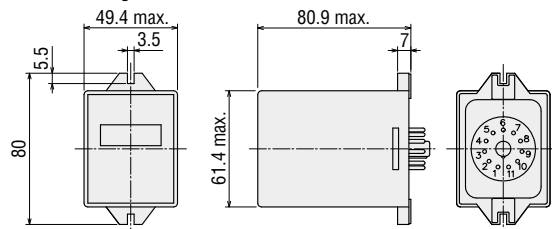

Dimensions with Adapter Attached (Unit = mm)

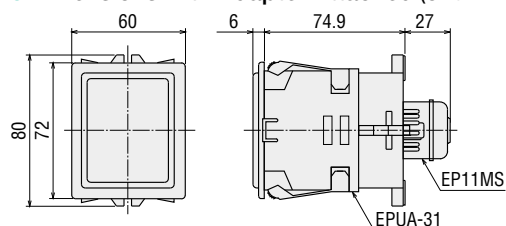

Panel Cut-Out

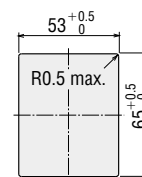

Flush Connecting Socket for Mounting DIN Rail RoHS

This flush connecting socket is convenient for mounting the motor speed indicator to the DIN rail with ease.

◇ Model: **EP11PF** (Sold Separately)

◇ Dimensions (Unit = mm)

Mass: 75 g

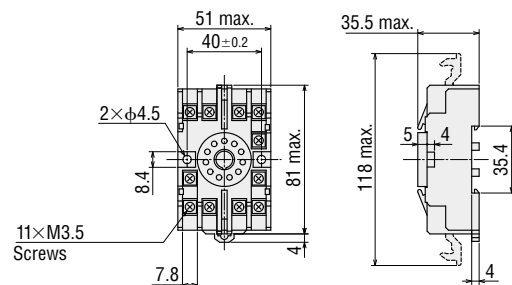

Motor/Gearhead Mounting Brackets (RoHS)

Mounting Brackets for attaching and securing a motor and gearhead. They are high-strength type, which can be used with high power motors/gearheads. These brackets come with tapped holes. To mount the motor and gearhead, simply fasten with the screws provided to the gearhead. To mount the motor alone, mounting screws must be provided separately.



Please note that these mounting brackets cannot be used with the following products.

- Right-Angle Gearheads (RH Type, RA Type)
- 5GU□K

For motor frame size: □60 mm

● Model: SOL2M4

Mass: 135 g Material: Aluminum

CAD A321

◇ Applicable Products

2GN Gearhead

Motor with the frame size of □60 mm

● Dimensions (Unit = mm)

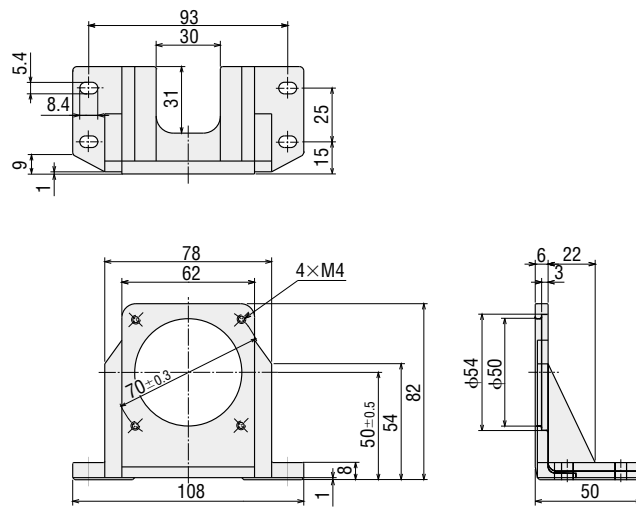

For motor frame size: □70 mm

● Model: SOL3M5

Mass: 175 g Material: Aluminum

CAD A322

◇ Applicable Products

3GN Gearhead

Motor with the frame size of □70 mm

● Dimensions (Unit = mm)

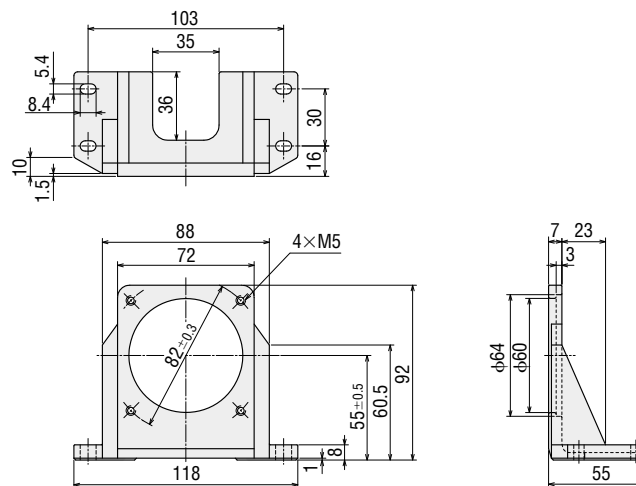

For motor frame size: □80 mm

● **Model: SOL4M5**
 Mass: 210 g Material: Aluminum
 CAD A236

◇ **Applicable Products**
4GN Gearhead
 Motor with the frame size of □80 mm

● **Dimensions (Unit = mm)**

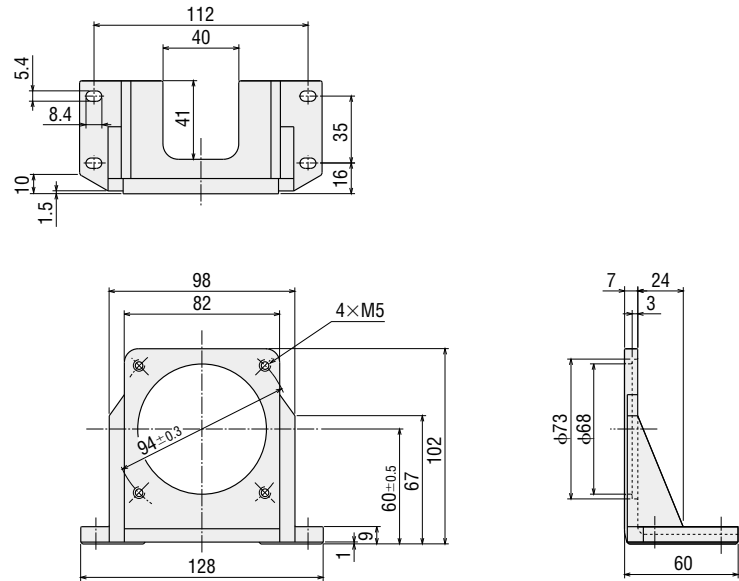

For motor frame size: □90 mm

● **Model: SOL5M6**
 Mass: 270 g Material: Aluminum
 CAD A238

◇ **Applicable Products**
5GN Gearhead
5GU□KB Gearhead
 Motor with the frame size of □90 mm

● **Dimensions (Unit = mm)**

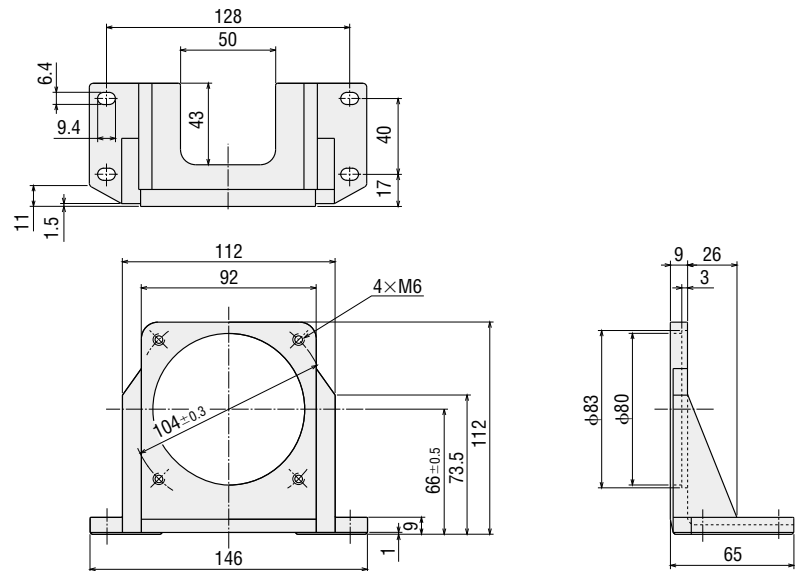

Flexible Couplings

These products are the clamping type couplings to connect between the shaft of motor/gearhead and the shaft of the equipment to be connected.

Once the motor and gearhead are determined, the coupling can be selected.



Features

- Couplings come with shaft holes and have standardized combinations for different diameter shaft holes.
- Characteristics are the same for clockwise and counterclockwise rotation.
- Oil-resistant and electrically insulated.
- Aluminum alloy construction.
- The shaft being driven is not damaged, since shafts are joined by clamping.
- Easy installation due to a separated hub and sleeve design.

Gearhead Model	Coupling Type
2GN□S	MCL20
	MCL30
3GN□S	MCL30
	MCL40
4GN□S	MCL30
	MCL40
5GN□S	MCL30
	MCL40
5GU□KB	MCL40
	MCL55
5GU□K	MCL55

* Type of coupling varies depending on condition of the load.

This product is manufactured at a plant certified with the international standards **ISO 9001** (for quality assurance) and **ISO 14001** (for systems of environmental management).

Specifications are subject to change without notice.
This catalogue was published in April, 2008.

Orientalmotor

SINGAPORE ORIENTAL MOTOR PTE LTD

31 Kaki Bukit Road 3, #04-02/04

TECHLINK, Singapore 417818

TEL: +65-6745-7344 FAX: +65-6745-9405

ORIENTAL MOTOR (THAILAND) CO., LTD.

900, 8th Floor Zone C, Tonson Tower, Ploenchit Road,

Lumpini, Pathumwan, Bangkok 10330 Thailand

TEL: +66-2-251-1871 FAX: +66-2-251-1872

Customer Support Centre

TEL: 1800-842-0280 (For Singapore)

1800-806161 (For Malaysia)

+65-6842-0280 (For Other Countries)

Mailto: support@orientalmotor.com.sg

ORIENTAL MOTOR (MALAYSIA) SDN. BHD.

Headquarters & Kuala Lumpur Office

A-13-1, North Point Offices, Mid Valley City,

No.1 Medan Syed Putra Utara 59200

Kuala Lumpur, Malaysia

TEL: +60-3-22875778 FAX: +60-3-22875528

Penang Office

TEL: +60-4-6423788 FAX: +60-4-6425788

Japanese Customer Support Centre

TEL: +65-6745-3008

Mailto: j-support@orientalmotor.com.sg

For more information please contact:



This printed material uses ECF (Elementary chlorine Free) paper and soy inks.
This combination is environmentally friendly.