

# Linear Heads

## Characteristics of Linear Heads

The three important characteristics of linear heads are specified below:

- Rack Speed
- Maximum Transportable Mass
- Holding Force

### Rack Speed

The rack speed of the **LH** linear head is stated by the base speed in the characteristics table of each product.

The base speed is calculated according to the motor synchronous speed (1500 r/min at 50 Hz). The actual motor speed changes depending on the load size.

Take note that when the **LH** linear head is combined with a speed control motor, the rack speed can be calculated from the motor speed using the formula below.

$$V = Ns \cdot \frac{1}{60} \cdot \frac{1}{i} \cdot \pi DP$$

$V$  : Traveling speed of rack [mm/s]

$Ns$ : Speed of combined motor [r/min]

$i$  : Gear ratio of linear head's reduction unit → Table below

$DP$ : Pitch circle diameter of pinion [mm] → Table below

### Maximum Transportable Mass

If the combined motor is not found in the characteristics table, the thrust force can be calculated from the torque generated by the motor using the formula below:

However, if the gear ratio is high or the actuator is used horizontally, the calculated thrust force permits driving of a load mass exceeding the mechanical strength of the gearhead. Regardless of the traveling direction of the rack, the load mass of the linear head should not exceed the maximum transportable mass specified for each type.

$$F = T_m \cdot i \cdot \eta_1 \cdot \frac{2}{DP} \cdot \eta_2$$

$$W = F/9.807$$

$T_m$ : Motor torque [mN·m]\*

$F$  : Thrust force [N]

$W$  : Transportable mass [kg]

$i$  : Gear ratio of linear head's reduction unit → Table below

$\eta_1$  : Transmission efficiency due to gear ratio → Table below

$DP$ : Pitch circle diameter of pinion [mm] → Table below

$\eta_2$  : Transmission efficiency of rack and pinion [=0.9]

\*Use the starting torque or rated torque, whichever is smaller, for calculation.

The maximum transportable mass in the characteristics table and calculated thrust force assume that the rack is moved horizontally. If the rack is moved vertically, the rack mass (refer to "Dimensions") or component force corresponding to the rack mass (rack mass × 9.807) must be subtracted from the value specified in the characteristics table.

### LH Linear Heads

Product Name	Gear Ratio $i$	Transmission Efficiency $\eta_1$	Pitch Circle Diameter of Pinion $DP$ [mm]
<b>0LB (F) 20N</b> -□	30	0.66	7.5
<b>0LB (F) 10N</b> -□	50	0.66	
<b>0LB (F) 5N</b> -□	100	0.59	
<b>2LF (B) 50N</b> -□	17.68	0.73	12
<b>2LF (B) 25N</b> -□	35.36	0.66	
<b>2LF (B) 10N</b> -□	86.91	0.59	
<b>4LF (B) 45N</b> -□	36	0.73	21.25
<b>4LF (B) 20N</b> -□	75	0.66	
<b>4LF (B) 10N</b> -□	150	0.66	

● A number indicating the stroke is specified in the box □ in the product name.

### Holding Force

The holding force can be calculated from the holding force of the combined motor using the formula below.

$$F_B = T_B \cdot i \cdot \frac{2}{DP}$$

$F_B$  : Holding force [N]

$T_B$  : Motor torque [mN·m]

$i$  : Gear ratio of linear head's reduction unit → Table on the left

$DP$ : Pitch circle diameter of pinion [mm] → Table on the left

The holding force in the characteristics table and calculated holding force assume that the rack is installed horizontally. If the rack is installed vertically, a force corresponding to the rack mass (refer to "Dimensions") (rack mass × 9.807) must be subtracted from the value specified in the characteristics table.

### Rack Play of LH Linear Heads (Initial values)

#### LH Linear Heads

The rack of the **LH** linear head is supported with two rack grommets in the rack case. Since a slight clearance is provided between the rack grommet and rack to allow for sliding on the inside of the rack grommet, the rack moves in the direction shown in the figure.

- Plays in directions A and B have been measured at 500 mm from the end face of the case. Play in direction D is larger because the rack is round.
- Rack play increases over time. If the rack plays become a problem, install an external guide.

Directions A and B	2 mm	or less
Direction C (Backlash)	0.5 mm	or less
Direction D	5°	or less

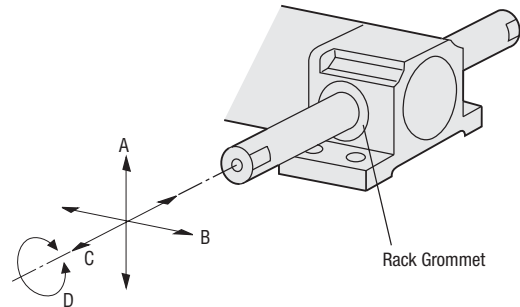

## ● Overrun (Reference value)

### ◇ LH Linear Heads

#### OL Type

Unit = mm

Motor \ Linear Head	OLB (F) 5N-□	OLB (F) 10N-□	OLB (F) 20N-□
<b>ORK1GN-AW3U</b>	1.4	2.8	4.7
<b>ORK1GN-AW3U</b> + Brake Pack <b>SB50W</b>	0.3	0.5	0.8

● The above overrun values are reference values assuming no load.

#### 2L Type

Unit = mm

Motor \ Linear Head	2LF (B) 10N-□	2LF (B) 25N-□	2LF (B) 50N-□
<b>2RK6GN-A (C) W2L2</b>	2.6	6.4	13
<b>2RK6GN-A (C) W2L2</b> + Brake Pack <b>SB50W</b>	0.7	1.6	3.2
<b>2RK6GN-A (C) W2ML2</b>	1.3	3.2	6.4
<b>2RK6GN-A (C) W2ML2</b> + Brake Pack <b>SB50W</b>	0.7	1.6	3.2

● The above overrun values are reference values assuming no load.

#### 4L Type

Unit = mm

Motor \ Linear Head	4LF (B) 10N-□	4LF (B) 20N-□	4LF (B) 45N-□
<b>4RK25GN-A (C) W2L2</b>	2.7	5.3	11
<b>4RK25GN-A (C) W2L2</b> + Brake Pack <b>SB50W</b>	0.7	1.3	2.8
<b>4RK25GN-A (C) W2ML2</b>	1.3	2.7	5.6
<b>4RK25GN-A (C) W2ML2</b> + Brake Pack <b>SB50W</b>	0.7	1.3	2.8

● The above overrun values are reference values assuming no load.

● A number indicating the stroke is specified in the box □ in the product name.

Selection Calculations

Motors

Motorized Actuators

Cooling Fans

Service Life

Standard AC Motors

Speed Control Motors

Stepping Motors

Servo Motors

Gearheads

Linear Heads

Motorized Actuators

Cooling Fans